

OCEOLA TOWNSHIP
1577 N. LATSON ROAD
HOWELL, MICHIGAN

ENGINEERING
DESIGN STANDARDS



Prepared by:

TETRA TECH
Brighton, Michigan

February 2010

CONTENTS

	Page
PART I. ENGINEERING DESIGN STANDARDS	
1.0 STORM SEWERS AND STORM WATER CONTAINMENT	1
1.01 Storm Water Management System	1
1.02 Sewer Locations	3
1.03 Detention Basins	3
1.04 Retention Basins	4
1.05 Underground Containment Systems	5
2.0 MUNICIPAL UTILITIES	6
2.01 Sanitary Sewer System	6
2.02 Water System	6
3.0 SITE GRADING AND SOIL EROSION CONTROL	7
3.01 Grading and Soil Erosion/Sedimentation Control Plan	7
3.02 Topographic Plan	7
3.03 Final Grading and Drainage Plan	8
3.04 Soil Erosion and Sedimentation Control Plan	9
4.0 PARKING LOT DESIGN	10
4.01 Basis of Design	10
4.02 Parking Lot Design	10
4.03 Intersection Design	11
5.0 PRIVATE ROAD DESIGN	12
5.01 Basis of Design	12
5.02 Right-of-Way and Street Width	13
5.03 Vertical Alignment	13
5.04 Horizontal Alignment	14
5.05 Intersections	14
5.06 Sight Distance	15
5.07 Cul-de-sacs	16
5.08 Pavement Design	16
5.09 Shared Driveways	17

6.0	CONSTRUCTION PROCESS	18
6.01	Submit Construction Plans to Township	18
6.02	Determination of Construction Permitting, Inspection, and Testing Responsibilities	18
6.03	Escrow Requirements	19
6.04	Preconstruction Meeting	20
6.05	Shop Drawings	20
6.06	Notice to Proceed Issued by the Township for Construction	20
6.07	Start Construction	20
6.08	Post-Construction	20
6.09	Final Construction Acceptance	21

Appendix A – Determination of Required Volume for Detention Basins: Sample Calculations

PART II. STANDARD DETAILS

R-1	Catch Basin
R-2	Outlet Control Structure
R-3	Trench Excavation & Backfill
G-1	Concrete Curb & Gutter
G-2	Concrete Curb Spillout
G-3	Sidewalk Ramp
G-4	Typical Residential Street
G-5	Roadway Cross Sections
G-6	Parking Lot Cross Sections
G-7	Typical Sidewalk Cross Sections

PART III. TECHNICAL SPECIFICATIONS

02240	Dewatering
02310	Earthwork
02315	Excavation and Backfill (Sewer and Water Main)
02630	Sewers
02635	Manholes & Catch Basins

02740	Hot Mix Asphalt Paving
02750	Portland Cement Concrete Paving
02805	Restoration Work
03315	Concrete Work (Sewers)

1.0 STORM SEWERS AND STORM WATER CONTAINMENT

1.01 Storm Water Management System

- a) A storm water management system basis of design shall be submitted with construction plans for approval by the Township Engineer. The basis of design shall include an area map indicating all tributary drainage areas and runoff coefficients, including off-site areas. The basis of design will reflect developmental phasing.

- b) All storm water management systems shall conform to the Standards set forth by the Livingston County Drain Commissioner.

- c) The use of Low Impact Development (LID) is encouraged. For more information, please see *Low Impact Development Manual for Michigan: A Design Guide for Implementers and Reviewers*, a LID manual put out by the Southeast Michigan Council of Governments (SEMCOG).

- d) All storm sewers shall be designed by a Rational Method for a 10-year storm, $Q = CIA$, where:
 - Q = total storm runoff flow, in cubic feet per second (cfs)
 - C = runoff coefficient (percent impervious area)
 - I = rainfall intensity rate (inches per hour)
 - A = tributary drainage area (acres)
 - 1) Rainfall intensity rate (I) shall be calculated from the Steel formula for a 10-year storm, $I = 175 / (t+25)$, where “t” = time of concentration (minutes). The minimum permissible value of “t” is 15 minutes.

 - 2) The runoff coefficient C shall be as recommended by ASCE Manual 37 *Design and Construction of Sanitary and Storm Sewers*. Where a weighted coefficient is employed, the computations shall be attached to project plans.

- e) Provisions shall be made for all off-site flow draining through the site.

- f) The minimum acceptable size for storm sewers constructed in public right-of-way or easement, including inlet/catch basin leads, shall be 12-inch diameter. Private storm sewers in paved areas shall be no less than 12-inch diameter. Private storm sewers in

lawn or landscape areas shall be no less than 6-inch diameter installed at 1.0 percent slope.

- g) Sewer velocities, capacity, and friction losses shall be based on Manning’s formula, generally with n=0.010 for plastic pipe, 0.013 concrete pipe, and 0.021 for corrugated metal pipe.

$$Q = A \frac{1.486}{n} r^{2/3} s^{1/2}$$

- h) The minimum design velocity for storm sewers shall be 2.5 feet per second (fps) with the pipe flowing full. Maximum design velocities shall be 10 fps.

Pipe Size	Minimum % of Grade 2.5 ft/sec	Desirable Range % of Grade		Maximum % of Grade 10 ft/sec
		4 ft/sec	8 ft/sec	
10"	0.40	1.00	3.98	6.22
12"	0.32	0.78	3.12	4.88
15"	0.24	0.58	2.32	3.62
18"	0.20	0.46	1.82	2.84
21"	0.16	0.38	1.48	2.30
24"	0.14	0.30	1.24	1.94
27"	0.12	0.26	1.06	1.66
30"	0.10	0.22	0.92	1.44
36"	0.08	0.18	0.72	1.12
42"	0.06	0.14	0.58	0.92
48"	0.06	0.12	0.50	0.76
54"	0.04	0.10	0.38	0.60
60"	0.04	0.10	0.34	0.54
66"	0.04	0.08	0.32	0.48

Riprap shall be placed as an erosion control measure for outlets with design velocities exceeding 4 fps. A minimum of ten (10) square yards of riprap with median stone size of 6 inches shall be placed over a heavy geotextile fabric at the outlet. Special consideration may be extended in reviewing maximum velocities of sewers serving areas of extreme topography.

- i) Hydraulic gradients shall be shown as a part of all storm sewer profiles. In no case, shall the elevation of the hydraulic gradient exceed the elevation of a point lying one (1) foot below the rim elevation of a manhole, catch basin, or inlet.

1.02 Sewer Locations

- a) Storm sewer shall be located in general conformance with the approved typical street cross-sections (see Details section).
- b) Where sewer placement in easements is approved, a permanent easement will be required, the width of which will be determined by the Township Engineer.
- c) Manhole and catch basins shall not be placed greater than 400 feet apart for sewers less than 30 inches in diameter and 600 feet apart for larger sewers.
- d) Inlet structures placed in the public right-of-way shall be spaced a maximum of 400 feet apart or a maximum of 400 feet from highpoints.
- e) The spacing and/or the number of inlets required to meet design flows in streets, private drives and parking areas shall be based on 1 cfs per 90 square inches of opening in an inlet or catch basin cover.

Manhole/Catch Basin Frame & Cover					
			Manufacturer or Equal		
Type	Location	Type of Cover or Inlet	East Jordan	Nee Nah	Maximum Drainage Area (acres)
MH	All	Vented	1040	R-1916 F1	N/A
CB	Type A Curb	Flat grate with Vertical open back	7000-T1-M1	R-3070	0.71
CB	Type B Curb	Flat Grate with Roll Back	7065-T1-M1	R-3034-B	0.87
CB	Pavement/Shoulder	Flat Grate	1020-MI	R-2060-D	0.66
CB	Open Area	Beehive Grate 4" High	1020-01	R-2560-D	0.63
CB	Gutter	Concave Inlet	5100	R-3238	0.96

1.03 Detention Basins

- a) Unless otherwise approved by the Township Engineer, each site shall have provision for on-site detention. Each site shall be capable of storing a volume of water required to limit the outflow to an agriculture rate (0.2 cfs/acre) or to a rate that the downstream properties can accept, whichever is less.
- b) The volume of storage provided for flood control will be equal to or in excess of that required by the Livingston County Drain Commissioner’s “A Simple Method of Detention Design” for a 100-year frequency storm. Sample calculations can be found in Appendix A.

- c) A minimum of one foot of freeboard will be required for all detention basins.
- d) The inlet and outlet of the detention basin shall be placed at opposite ends of detention basin.
- e) A sediment forebay shall be provided at the inlet of all detention basins. The capacity of the forebay shall be equivalent to 5% of the 100-year storm volume.
- f) A defined emergency spillway shall be provided.
- g) Detention basin side slopes shall not exceed 3:1 side slopes without the use of fencing.
- h) Planned ponding on parking lots is not to be considered an acceptable method of providing storm water detention.
- i) A landscape plan, for the area surrounding the proposed detention basin and meeting requirements from the Oceola Township Zoning Ordinances, shall be provided.

1.04 Retention Basins

- a) A retention basin provides storage of water for a lengthy period of time, and drains through evaporation/infiltration. Use of retention basins is discouraged, and shall be permitted only upon approval of the Township Engineer and the Livingston County Drain Commissioner.
- b) An overflow assessment will be required. The assessment should include descriptions of the surrounding areas, including nearby homes, which would be impacted in the event of an overflow. The overflow assessment shall include a defined emergency overflow spillway.
- c) Retention basins shall be sized to store two inches of runoff from the entire tributary area from a 100-year frequency storm. The Township Engineer reserves the right to require additional storage up to that required by two consecutive 100-year storm events based on the results of soils data or the overflow assessment. If such additional storage is required, freeboard requirements may be reduced at the discretion of the Township Engineer and the Livingston County Drain Commissioner.

- d) Soil borings 20 feet below the proposed basin bottom must be provided. The documented high level of the groundwater shall be provided.
- e) A minimum of three feet of freeboard will be required for all retention basins.
- f) A sediment forebay shall be provided at the inlet of all retention basins. The capacity of the forebay shall be equivalent to 5% of the entire volume.
- g) Retention basin side slopes shall not exceed 3:1 side slopes without the use of fencing.
- h) A landscape plan, for the area surrounding the proposed retention basin and meeting requirements from the Oceola Township Zoning Ordinances, shall be provided.

1.05 Underground Containment Systems

- a) Use of underground containment systems is discouraged, and shall be permitted only upon approval of the Township Engineer and the Livingston County Drain Commissioner.
- b) If approval is granted, the underground containment system shall meet all established standards for the type of system that is proposed.

MUNICIPAL UTILITIES

2.01 Sanitary Sewer System

- a) A joint venture between Oceola Township and Genoa Township, referred to as the Genoa-Oceola (GO) Sanitary Sewer System provides service to the southwestern portion of Oceola Township.

- b) The most recent Marion, Howell, Oceola, Genoa Sewer and Water Authority and Genoa-Oceola Sewer and Water Authority Sanitary Sewer and Water Design Standards shall be used for all municipal sanitary sewer design standards.

2.02 Water System

- a) A joint venture between Oceola Township and Marion, Howell, and Genoa Townships, referred to as the Marion, Howell, Oceola, Genoa (MHOG) Water System provides service to the southwestern portion of Oceola Township.

- b) The most recent Marion, Howell, Oceola, Genoa Sewer and Water Authority and Genoa-Oceola Sewer and Water Authority Sanitary Sewer and Water Design Standards shall be used for all municipal water design standards.

3.0 SITE GRADING AND SOIL EROSION CONTROL

3.01 Grading and Soil Erosion/Sedimentation Control Plan

- a) A comprehensive grading and soil erosion/sedimentation control plan shall be submitted for any project involving over one (1) acre of disturbance.

- b) The plan shall be prepared in accordance with the *Soil Erosion and Sedimentation Control Guidebook* by the Michigan Department of Environmental Quality and such other criteria as may be established by the local enforcing agent for the Soil Erosion and Sedimentation Control Act (Part 91 of Act 451 of Public Acts of 1994).

3.02 Topographic Plan

- a) The topographic plan shall be prepared at a scale of not less than one inch equals forty feet (1:40 scale) for properties of one acre or less, or not less than one inch equals one hundred feet (1:100 scale) for properties greater than one acre.

- b) The topographic plan shall be prepared based on NGVD datum, with a contour interval not greater than two feet. The benchmark(s) should be noted on the plan.

- c) The topographic plan shall include all natural features, including, but not limited to, flowing streams or ditches, intermittent watercourses, lakes, ponds, marshes and swamps, wetlands limits as defined by the Goemaere-Anderson Wetlands Protection Act (Part 303 of Act 451 of PA of 1994), wooded areas, and trees as defined by the Oceola Township Zoning Ordinance.

- d) The topographic plan shall include all existing man-made features, including, but not limited to buildings, pavement structures, soil stockpiles, and retaining walls. The plan shall clearly note any such features proposed for demolition and removal from the site.

- e) The topographic plan shall also provide information as to the on-site soils, as may be obtained from on-site borings or excavations, or the USDA Soils Conservation Service Soils Maps.

3.03 Final Grading and Drainage Plan

- a) Grading plans shall consider desirable natural features and the character of the land, and shall preserve such features where possible.
- b) The plan shall present all proposed site features with complete dimensions, including buildings, roads, parking lots, walks, drives, retaining walls, retention basins, sediment basins, drainage facilities, and lawn areas.
- c) The plan shall show final grade elevations of finished floor and basement floor elevations for proposed structures, high and low points, swales and ridge lines, flow lines at drainage structures, and other significant points in sufficient detail to demonstrate the proposed surface flow patterns.
- d) All proposed developments shall be graded such that storm water runoff will be intercepted within the boundaries of the site, collected, and conducted through an enclosed storm water system or vegetated swale/open ditch to an approved point of discharge. Drainage provisions shall be designed in accordance with Section 1.0, Storm Sewers and Storm Water Containment.
- e) Maximum slope for any paved area is five (5) percent. Minimum slope is 0.5 percent for a road and 1.0 percent for a paved parking area. Variations may be considered where significant topographic constraints warrant, provided the designer justifies the variation in writing, demonstrating the impact on the project if the variation is not approved, and discussing any measures taken to mitigate the consequences of steeper or flatter slopes.
- f) Maximum slope for a non-paved area is three-foot horizontal to one-foot vertical (3:1 slope). No slope may be in excess of 3:1 without the use of a retaining wall.
- g) The plan shall contain stamped structural calculations for retaining walls within a slope of one-foot horizontal to one-foot vertical (1:1 slope) of any parking lot, building or structure.
- h) In single-family subdivisions and condominium developments, typical lot grading details shall be included on the grading plan.

3.04 Soil Erosion and Sedimentation Control Plan

- a) The soil erosion and sedimentation control plan shall identify all areas of potential accelerated soil erosion and shall identify specific measures to be utilized, both temporarily during construction and permanently, to control erosion. The measures shall be identified on the plan by means of the Unified Soil Erosion Control Key System.
- b) The plans shall identify the acreage of the area to be disturbed.
- c) The plans shall include a schedule of installation of temporary and permanent soil erosion and sedimentation control measures. The developer shall maintain all temporary measures in good repair until permanent stabilization measures have been established and proved effective.
- d) Wetlands areas, streams, and ponds shall be protected by silt fence installed before topsoil is stripped from any upland area.
- e) Trees and wooded areas identified as preserved on the approved site plan must be fenced off from the construction zone with safety fence before topsoil is stripped from the site.

4.0 PARKING LOT DESIGN

4.01 Basis of Design

- a) All parking lot approaches shall be designed in general accordance with the latest Standards set forth by Oceola Township and the Livingston County Road Commission (LCRC). Copies of all calculations and drawings verifying compliance with LCRC and Township Standards are to be submitted for review of the Township Engineer.
- b) For each development, sufficient parking stalls, as required in the Oceola Township Zoning Ordinance, shall be provided. Sufficient signed and marked barrier free spaces, as required, shall be provided.
- c) Adequate ingress and egress to the parking facility shall be provided by clearly defined driveways. Parking lots shall be designed to prevent vehicles from backing into the street or requiring use of the street for maneuvering between parking rows.
- d) For each development, the number of trips generated per hour shall be included. Trip generation rates from *Trip Generation* by the Institute of Transportation Engineers (ITE) shall be utilized. A traffic circulation plan including trip generation/distribution models shall be developed for any development in excess of 50 trips per hour. The traffic circulation plan shall consider adjacent properties and their development potential.

4.02 Parking Lot Design

- a) Parking lot pavement cross sections shall be designed based on existing soil conditions and shall accommodate the types of traffic loads anticipated. Minimum pavement cross sections can be seen below and in the Details.

Light-Duty Parking Lot

- 1-1/2" Bituminous wearing course MDOT mix 36A.
- 1-1/2" Bituminous leveling course MDOT mix 13A. Use 0.10 gal/sq. yd. bond coat between courses.
- 6" MDOT No. 22A aggregate base C.I.P.
- 6" MDOT Cl. II granular subbase C.I.P.

Industrial Parking Lot

- 1-1/2" Bituminous wearing course MDOT mix 36A.
- 4" Bituminous leveling course MDOT mix 13A (installed in two courses). Use 0.10 gal/sq. yd. bond coat between courses.
- 8" MDOT No. 22A aggregate base C.I.P.
- 6" MDOT Cl. II granular subbase C.I.P.

Concrete Parking Lot

- 6" Class A Concrete
- 6" MDOT Cl. II granular subbase C.I.P.

- b) Areas subject to heavy truck traffic must be designed with an adequate pavement structure, designed to accommodate the anticipated loads.
- c) Alternate pavement designs shall be designed in accordance with the AASHTO *Guide for Design of Pavement Structures*, latest edition. The Design Engineer shall submit detailed calculations, including justification for design parameters and traffic estimates, including load calculations.
- d) All parking spaces and maneuvering aisles shall be designed and marked with dimensions described below:

Parking Alignment	Parking Space Dimensions		Aisle Width	
	Width	Length	Two-Way	One-Way
75 – 90 Degree	10 feet	20 feet	24 feet	20 feet
54 – 74 Degree	10 feet	20 feet	24 feet	15 feet
30 – 53 Degree	10 feet	20 feet	24 feet	12 feet
Parallel	8 feet	23 feet	24 feet	12 feet

- e) Concrete curbing (as shown in the Details section) shall encompass the entirety of the parking lot. Variances may be granted for sites that use Low Impact Development.
- f) Parking lot grades shall be at a minimum 1.0% and at a maximum 5.0%.

4.03 Intersection Design

- a) Driveway intersections shall meet all standards set in Section 5.05 - Intersections.

5.0 PRIVATE ROAD DESIGN

5.01 Basis of Design

- a) All streets shall be designed in general accordance with the latest Standards set forth by Oceola Township and the Specifications for Plat Development by the Livingston County Road Commission (LCRC). Copies of all calculations and drawings verifying compliance with LCRC and Township Standards are to be submitted for review of the Township Engineer.
- b) The number of trips generated per hour shall be included. Trip generation rates from *Trip Generation* by the Institute of Transportation Engineers (ITE) shall be utilized. A traffic circulation plan including trip generation/distribution models shall be developed for any development in excess of 50 trips per hour.
- c) Streets shall be classified in a street hierarchy system with design tailored to function as described below:

ARTERIAL - The function of these streets is to serve as the principal carrier of high-volume traffic flow connecting areas of principal traffic generation and carrying traffic into and away from urban areas. Arterials should form a continuous and integrated system, shaping and defining areas of conflicting land use.

COLLECTOR - The function of these streets is to carry traffic between arterial and local streets and to provide access to adjacent residential neighborhoods. Streets serving over 75 dwelling units or serving primarily commercial properties shall be classified as collectors. It is anticipated that vehicles larger than a single unit (SU) truck will travel these streets (i.e., semi-tractor trailers (WB-50)).

INDUSTRIAL - These streets are defined by adjacent land use. Street design shall consider the geometric and structural demands of heavy truck traffic.

LOCAL - These streets function solely to provide access to residential lots immediately adjacent to the street. These streets shall carry maximum average daily traffic (ADT) of 1000 trips/day and serve 75 dwelling units or less.

ALLEYS - Alleys are defined by the historic function of providing access to rear lots.

- d) The minimum design speed of any residential or industrial street shall be 30 mph. Collector and arterial streets shall be designed for a minimum design speed of 40 mph. Greater design speeds may be required for any street as required by the Township Engineer and/or the Township Board.
- e) A plan detailing placement of traffic control devices (signage, striping, etc.) shall be submitted for review of the Township Engineer. The traffic control plan shall be prepared in accordance with the *Michigan Manual of Uniform Traffic Control Devices (MMUTCD)*.

5.02 Right-of-Way and Street Width

- a) The minimum right-of-way width and street width as measured from edge-of-metal to edge-of-metal (E/E) shall be as follows:

<u>Classification</u>	<u>R.O.W. Width</u>	<u>Street Width (E/E)</u>
Arterial	varies	varies
Collector	66	30
Industrial	66	30
Local	66	30
Alley	varies	varies
Cul-de-sacs	75 (radius)	60 (radius)

- b) A typical street cross-section is included in the Part II Standard Details.

5.03 Vertical Alignment

- a) Street grades shall meet the following requirements:

<u>Classification</u>	<u>Min. Grade</u>	<u>Max. Grade</u>
Arterial	0.5 percent	5.0 percent
Collector	1.0 percent	5.0 percent
Industrial	1.0 percent	5.0 percent
Local	1.0 percent	6.0 percent

Variations from these grades may be permitted by Township Engineer if topographic conditions warrant.

- b) All streets shall have a minimum 2.0 percent transverse crown centered in the cross-section.
- c) Vertical curves are required at all intersecting grades where the change exceeds 1.0 percent. No vertical curve of less than 100 feet shall be used.
- d) Grades within street intersections shall not exceed 3.0 percent for a distance of 100 feet from the intersection of the street intersections.

5.04 Horizontal Alignment

- a) Street jogs with centerline offsets of less than 125 feet shall not be permitted.
- b) Tangents shall be introduced between reverse curves, in accordance with AASHTO standards. Minimum tangent length between reverse curves shall be equal to the travel distance in three seconds at the design speed.
- c) Compound curves should be used in lieu of “broken-back curves” (successive curves in the same direction with a tangent of one second travel time or less). The flatter curve shall not have a radius of more than 1.5 times the sharper curve.
- d) Horizontal curves shall be designed in accordance with AASHTO standards for the appropriate design speed. The calculated minimum curve radius shall apply to the centerline of the inside traveled lane. Superelevation shall not be considered unless specifically approved by the Township Engineer.

5.05 Intersections

- a) Street intersections shall be as near to a 90-degree angle as possible, but in no event shall the intersection angle be less than 80 degrees.
- b) The minimum offset distance between opposing intersections shall be 125 feet.
- c) Vertical grades at the intersection shall be no greater than three (3) percent for a distance of 100 feet from the centerline of the intersection. Vertical curves shall be provided. No vertical curve of less than 100 feet shall be used.
- d) Intersection curb radii for the various street classifications are as follows (measured at the back of curb):

<u>Classification</u>	<u>Intersection Radii</u>
Arterial	35 feet
Collector	35 feet
Industrial	35 feet
Local	30 feet

Where streets of differing classifications intersect, the larger required radius shall govern.

- e) The minimum grade around intersection radii shall be 0.5 percent along the gutter. The curb grades may be independent of the street centerline grade to meet this requirement.
- f) Low spots in intersections shall not be allowed. Drainage must be carried away from the intersection.
- g) Detail drawings of intersections may be required by the Township Engineer. The details shall include adequate spot elevations to ensure that pavement and gutters will drain properly and meet Township Standards.

5.06 Sight Distance

- a) A continuous minimum stopping sight distance shall be provided along the vertical and horizontal alignments in accordance with AASHTO Standards as follows:

<u>Speed Limit (mph)</u>	<u>Required Sight Distance (feet)</u>	
	<u>Standard</u>	<u>Minimum Allowable</u>
30 or below	350	260
35	400	300
40	450	335
45	500	375
50	550	410
55	600	450

The line of vision shall be measured from a point 4.5 foot above the pavement to an assumed driver's eye height of 3.5 feet above the pavement.

5.07 Cul-de-sacs

- a) All dead-end streets shall terminate in a cul-de-sac. Where cul-de-sacs represent a permanent termination of a proposed street, the maximum length of road shall be 1000 feet from intersection to center of cul-de-sac.
- b) The cul-de-sac right-of-way radius shall be 75 feet. The outside radius of the cul-de-sac (at edge of metal) shall be 60 feet. A 35-foot radius landscape island may be permitted in the center of residential cul-de-sacs, at the discretion of the Township Engineer, provided low-maintenance ground cover or landscape material is proposed, and an adequate mechanism for perpetual maintenance of the landscaping is developed.
- c) Pavement grades in the cul-de-sac bulb shall have a minimum cross grade of two (2) percent. Grades along the curb shall be minimum 0.5 percent. A detail drawing of each cul-de-sac bulb is required, with adequate spot elevations to demonstrate proper drainage and compliance with Township standards.

5.08 Pavement Design

- a) Minimum pavement cross-sections are included in the Details. Pavement edge drain is considered standard, but may be waived at the discretion of the Township Engineer if adequate soils information is provided to justify an alternate means of subbase drainage.

Residential Bituminous Road

- 1-1/2" bituminous wearing course MDOT mix 36A.
- 1-1/2" bituminous leveling course MDOT mix.13A. Use 0.10 gal/SY bond coat between courses.
- 8" MDOT No. 22A aggregate base.
- 10" MDOT Cl. II granular subbase C.I.P.

Industrial Bituminous Road

- 1-1/2" bituminous wearing course MDOT mix 36A.
- 5" bituminous aggregate leveling course MDOT mix 13A (2 courses). Use 0.10 gal/SY bond coat between courses.
- 10" MDOT No. 22A aggregate base.
- 12" MDOT Cl. II granular subbase C.I.P.

Concrete Road

- 6" Class A Concrete
- 6" MDOT Cl. II granular subbase C.I.P.

Gravel Road

- 7" MDOT No. 22A wearing course
- 6" MDOT Cl. II granular subbase C.I.P.

- b) The developer shall submit soil boring logs for all industrial or collector streets. The borings shall be located no more than 500 feet apart, in both traffic lanes. Additional borings are required where vegetation, drainage patterns, or other factors suggest a change in soil type or groundwater conditions. No fewer than six borings shall be provided for any collector road, regardless of length.

The borings record shall include a classification of soils encountered and groundwater conditions. If soil conditions are unfavorable, the Township Engineer may require the developer to prepare and submit an alternate pavement design.

- c) Alternate pavement designs may also be initiated by the developer provided adequate soils information and traffic data are provided. Alternate pavement cross-sections must equal or exceed the structural strength of the standard cross-sections.

5.09 Shared Driveways

- a) Two (2) single family lots may have access from a shared private driveway upon approval from the Township Supervisor.
- b) Shared driveways shall meet all requirements for Flag Lots set forth in the Oceola Township Zoning Ordinances.

6.0 CONSTRUCTION PROCESS

The following is the recommended procedure for the submittal and approval of Construction Drawings for development within the Township. The procedure lists the process and the responsible party from the initial submittal to the Township through construction and final acceptance by the Township. Note: Municipal sanitary sewer and water main construction is not included in this section. Refer to Section 2.0 – Municipal Utilities for more information.

6.01 Submit Construction Plans To Township

- Upon receipt of necessary site plan approvals, the Developer's Engineer shall provide Oceola Township with construction drawings for use in reviewing the proposed improvements.
- Township to forward construction plans to Engineering Consultant and appropriate staff / department.
- Once approval from the Township is obtained, the Developer may proceed with the construction process.

6.02 Determination Of Construction Permitting, Inspection, And Testing Responsibilities:

- Land Use Permit – Developer shall apply for a land use permit from the Township.
- Necessary Governmental Agency Construction Permits – Developer is ultimately responsible for obtaining all required permits for construction.
- Easements – Developer is to obtain and provide copies of acquired easements to Township.
- Livingston County Drain Commission Approval – Required for all sites adjacent to or outlets to County Drain.
- Soil Erosion and Sedimentation Control (SESC) Permit - Developer shall apply for SESC permit. A letter from the Township Engineer stating that the construction drawings have been designed in general conformance to the Livingston County Drain Commission (LCDC) standards will be required prior to LCDC issuance of the SESC permit.
- Livingston County Road Commission Approval – Required for all work within County road right-of-way.

- Michigan Department of Transportation Approval – Required for all work within State road right-of-way.

Inspection Responsibilities:

- Storm Sewer and Storm Water Basins – typ. Developers Engineer
- Road and Pavements – typ. Developers Engineer
- Survey (setting controls and construction staking) – typ. Developers Engineer

Construction Testing Responsibilities:

- Compaction Testing (Road and Pavement) – Developer
- Compaction Testing (Storm Sewer) – Developer
- Television Inspection (Storm Sewer) – Developer
- Ring Deflection Testing (Storm Sewer) – Developer
- Air Testing (Storm Sewer) – Developer
- Infiltration/Exfiltration Testing (Storm Sewer) - Developer

6.03 Escrow Requirements

- An opinion of probable construction cost will be submitted to the Township by the Developer's Engineer.
- The Township Engineer will review the OPC and determine an escrow amount required to provide the necessary construction services.
- If the Developer and Township Engineer can not agree on the escrow amount, the Township Board shall make a final determination.
- Developer will be required to escrow this amount with the Township prior to construction.
- The escrow amount will be held until the Developer's engineer provides certification of completion for any private roadway or storm sewer improvements. The escrow will be released in full or partial upon receiving certification documents and a final walk through by a Township representative.

6.04 Preconstruction Meeting

- Developer's Contractor to provide general liability insurance naming the Township and the Township's Engineer as additional insured's. The amount will be determined by the Township.
- Developer's Contractor to provide a preliminary schedule of construction activities.

6.05 Shop Drawings

- The Developer's Contractor shall submit shop drawings to the Township Engineer for review.
- No construction will be allowed to start on any improvements without approved shop drawings.

6.06 Notice To Proceed Issued By The Township For Construction

- Contractor's certificate of insurance submitted and approved.
- Escrow and Bond amounts determined by Township are provided.
- Performance guarantee / sureties submitted to Township.
- Necessary information submitted to Township for start of construction. Necessary information may include, but is not limited to, copies of issued construction permits, schedule of construction activities, list of contractor contacts and emergency numbers, and copies of easements necessary for construction activities.

6.07 Start Construction

- Developer's Contractor to contact Township Engineer for notification of construction start.

6.08 Post-Construction

- Developer's Design Engineer to incorporate 'red-line' comments on the Conforming to Construction Record Drawings.
- Construction Engineer to finalize project file including lead sheets and daily reports.

6.09 Final Construction Acceptance

The Township will accept the construction only after the following have been submitted:

- Conforming to Construction Record Drawings
- Satisfactory results of all construction testing
- Road and Pavement Certifications
- Storm Sewer Certifications
- Service lead sheets
- Daily construction reports
- Operation and maintenance manuals
- Warranties and guarantees
- Waivers of liens

Written confirmation by Engineer that the construction has been performed in general conformance with the approved construction documents shall be obtained prior to placing municipal facilities in service.

APPENDIX A

Determination of Required Volume for Detention Basins: Sample Calculations

Appendix A: Determination of Required Volume for Detention Basins Sample Calculations

Tributary Area (A) = _____ Acres
 Run-off Coefficient* (C) = _____
 Design Constant (K_1) = A x C = _____
 Allowable Outflow Rate (Q_o) = 0.2 cfs/acre x A = _____ cfs

1	2	3	4	5	6	7
Duration (Minutes)	Duration (Seconds)	Intensity (100-yr Storm: $I=275/t+25$) (in/hr)	Col. # 2 x Col. # 3 (in)	Inflow Volume = Col. # 4 x K_1 (Cu. Ft.)	Outflow Volume = Col. # 2 x Q_o (Cu. Ft.)	Storage Volume = Col. # 5 - Col. # 6 (Cu. Ft.)
5	300	9.17	2,751			
10	600	7.86	4,716			
15	900	6.88	6,192			
20	1,200	6.11	7,332			
30	1,800	5.00	9,000			
60	3,600	3.24	11,664			
90	5,400	2.39	12,906			
120	7,200	1.90	13,680			
180	10,800	1.34	14,472			

*Computations for compound run-off coefficients shall accompany all design plans.

OCEOLA TOWNSHIP STANDARD DETAILS

SHEET	DESCRIPTION
R-1	CATCH BASIN
R-2	OUTLET CONTROL STRUCTURE
R-3	TRENCH EXCAVATION & BACKFILL
G-1	CONCRETE CURB & GUTTER
G-2	CONCRETE CURB SPILLOUT
G-3	SIDEWALK RAMP
G-4	TYPICAL RESIDENTIAL STREET
G-5	ROADWAY CROSS SECTIONS
G-6	PARKING LOT CROSS SECTIONS
G-7	TYPICAL SIDEWALK CROSS SECTIONS

Oceola Township

LEGEND

Date: FEBRUARY 2010

10 February 2010 DRAWING: P:\VER\12776\200-12776-00-000\Support\Docs\Standards\Codes\Oceola Township Design Standards\February 2010\CAD\OCEOLA-STD .DWG

MANHOLE FRAME & COVER & CATCH BASIN INLETS					
TYPE	LOCATION	MANUFACTURER OR EQUAL		TYPE OF COVER OR INLET	MAXIMUM DRAINAGE AREA (ACRES)
		EAST JORDAN	NEENAH		
MH	ALL	1040	R-1916 F1	SANITARY-SOLID SELF-SEALING STORM-VENTED	N/A
CB	TYPE A CURB	7000-T1-M1	R-3070	FLAT GRATE WITH VERT. OPEN BACK	0.71
CB	TYPE B CURB	7065-T1-M1	R-3034-B	FLAT GRATE WITH ROLL BACK	0.87
CB	PAVEMENT/ SHOULDER	1020-M1	R-2060-D	FLAT GRATE	0.66
CB	OPEN AREA	1020-01	R-2560-D	BEEHIVE GRATE 4" HIGH	0.63
CB	GUTTER	5100	R-3238	CONCAVE INLET	0.96

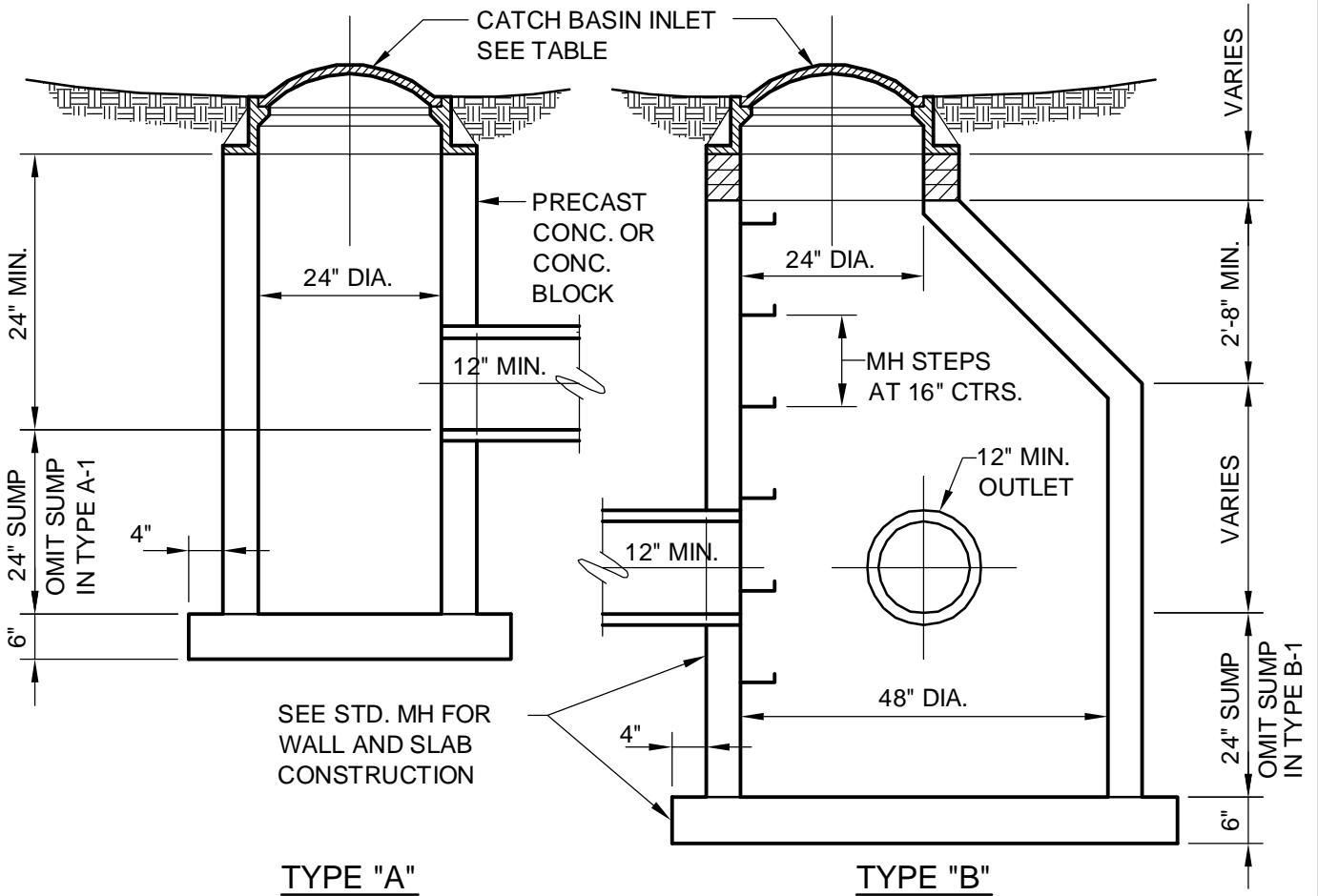

TYPE "A"

TYPE "B"

NOTE:
TYPE A-1 EQUAL TO TYPE "A" EXCLUDING 24" SUMP BUT ADD ON BOTTOM CONC. FILLET.

NOTE:
TYPE B-1 EQUAL TO TYPE "B" EXCLUDING 24" SUMP BUT ADD ON BOTTOM CONC. FILLET.

Oceola Township

CATCH BASIN

Date: FEBRUARY 2010

R-1

10 February 2010 DRAWING: P:\VER\12776\200-12776-00-000\SupportDocs\Stds-Codes\Oceola Township Design Standards\February 2010\CAD\OCEOLA-STD .DWG

WELD 1/2" BARS AT 3" O.C. AND
 WELD GRID TO 3"x1/4" ANGLE.
 SECURE TO CMP WITH 1/4"
 STAINLESS STEEL SCREWS.
 WELDS TO CONFORM TO
 CURRENT ANS. STANDARDS

BACKFILL WITH 3" WASHED
 STONE, THEN CHOKE WITH
 MDOT 6A STONE WRAP
 STRUCTURE WITH NON WOVEN
 POLYESTER OR POLYPROPYLENE
 GEOTEXTILE FABRIC AMOCO 4500
 OR 2000 SERIES OR EQUAL.

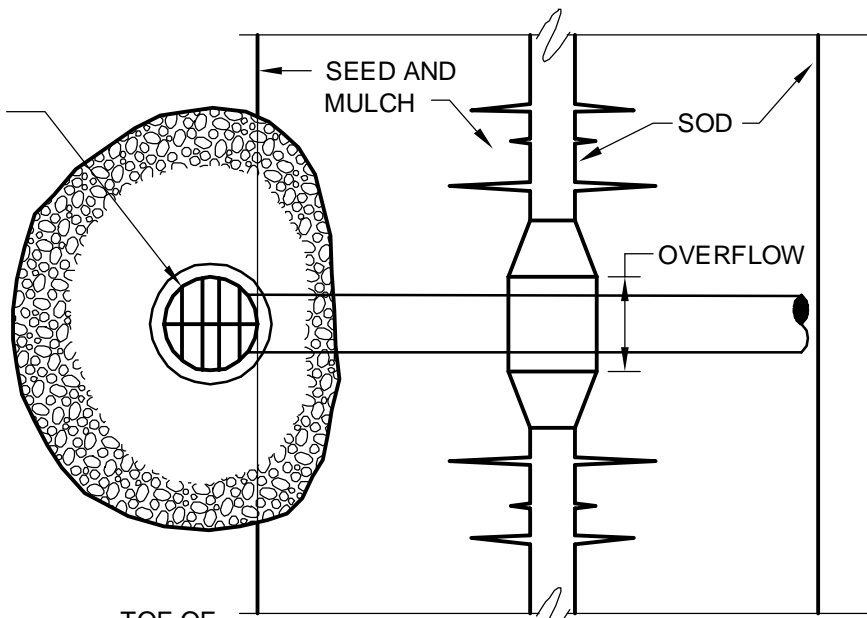

PLAN VIEW

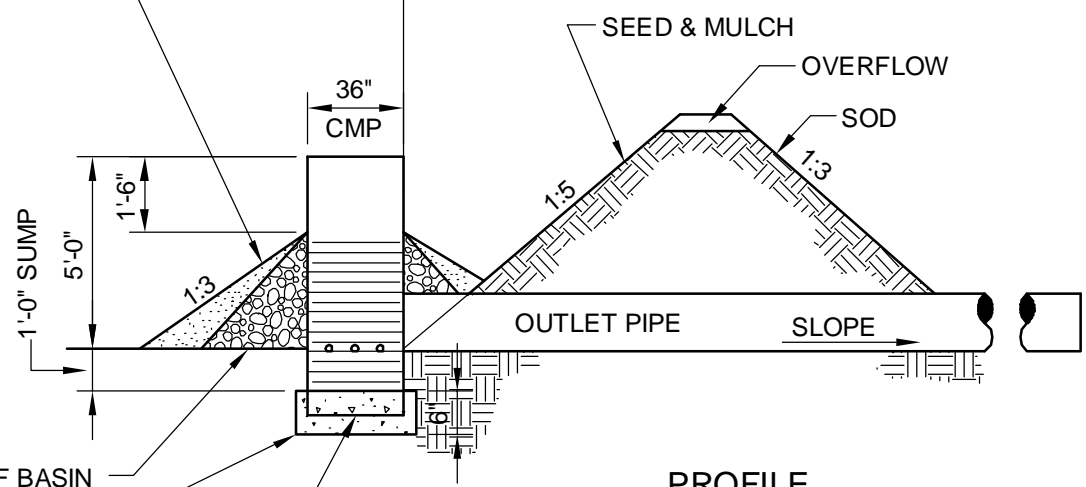

PROFILE

BOTTOM OF BASIN
 4' DIA. CONCRETE BASE
 EMBED CMP PIPE INTO CONCRETE
 BASE (MDOT CLASS A)

Oceola Township

OUTLET
 CONTROL STRUCTURE

Date: FEBRUARY 2010

R-2

NOTES:

1. COMPACTION PRESENTED AS STANDARD PROCTOR VALUES.

<u>SOIL TYPES</u>	<u>ASTHO DESIG.</u>
GRAVEL SANDY (SW)	A1, A3
SANDY SILTY (ML)	A2, A4
SILTY CLAY (CL)	A5, A6, A7

3. SOIL IN HAUNCH AND LOWER SIDE ZONES OUTSIDE OF $D_o/6$ FROM SPRING LINE SHALL BE COMPACTED TO AT LEAST THE SAME COMPACTION AS THE SOIL IN THE OVERFILL ZONE.

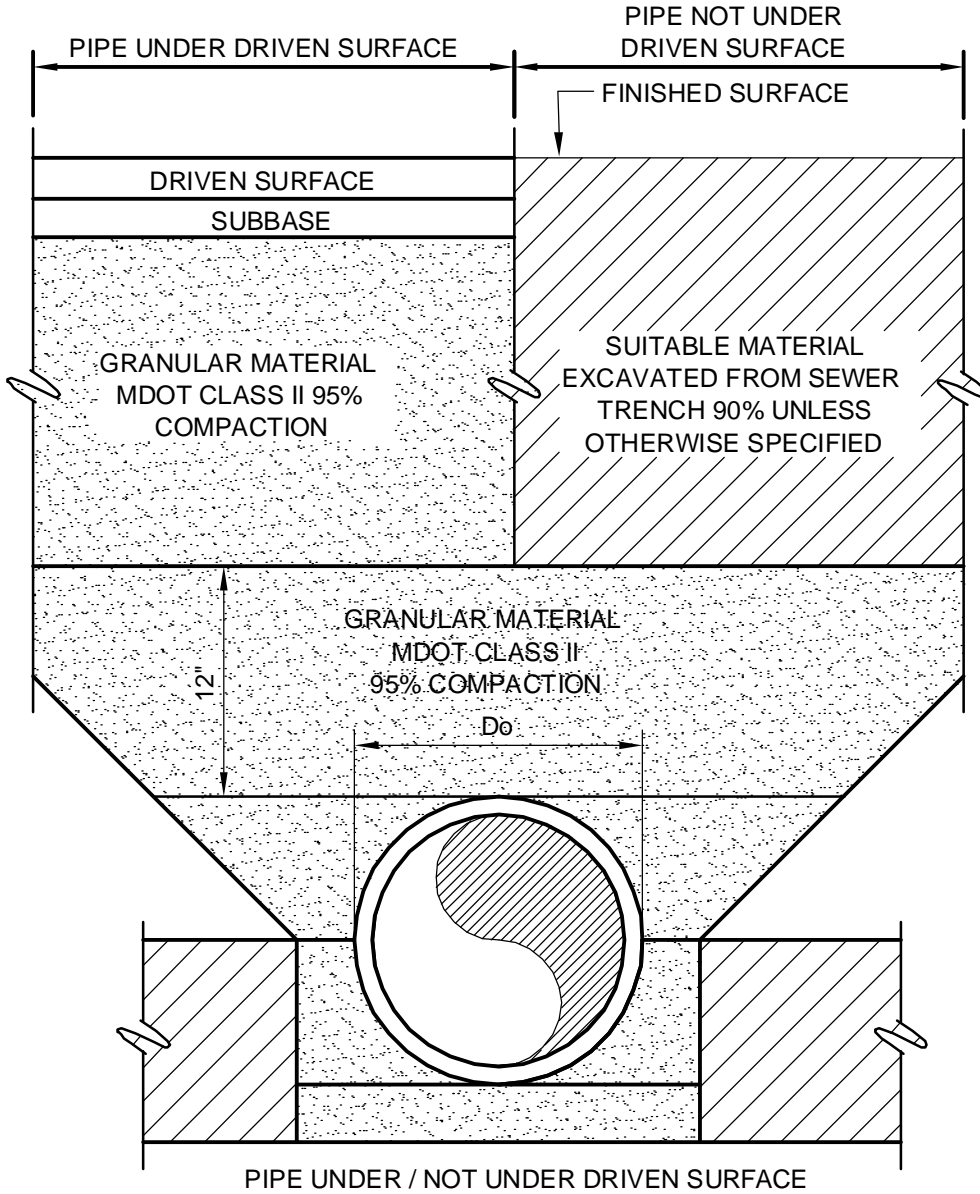

10 February 2010 DRAWING: P:\VER\12776\200-12776-00-000\SupportDocs\Std-Codes\Oceola Township Design Standards\February 2010\CAD\OCEOLA-STD .DWG

Oceola Township

TRENCH
EXCAVATION & BACKFILL

Date: FEBRUARY 2010

R-3

10 February 2010 DRAWING: P:\VER\12776\200-12776-00-000\SupportDocs\Std-Codes\Oceola Township Design Standards\February 2010\CAD\OCEOLA-STD .DWG

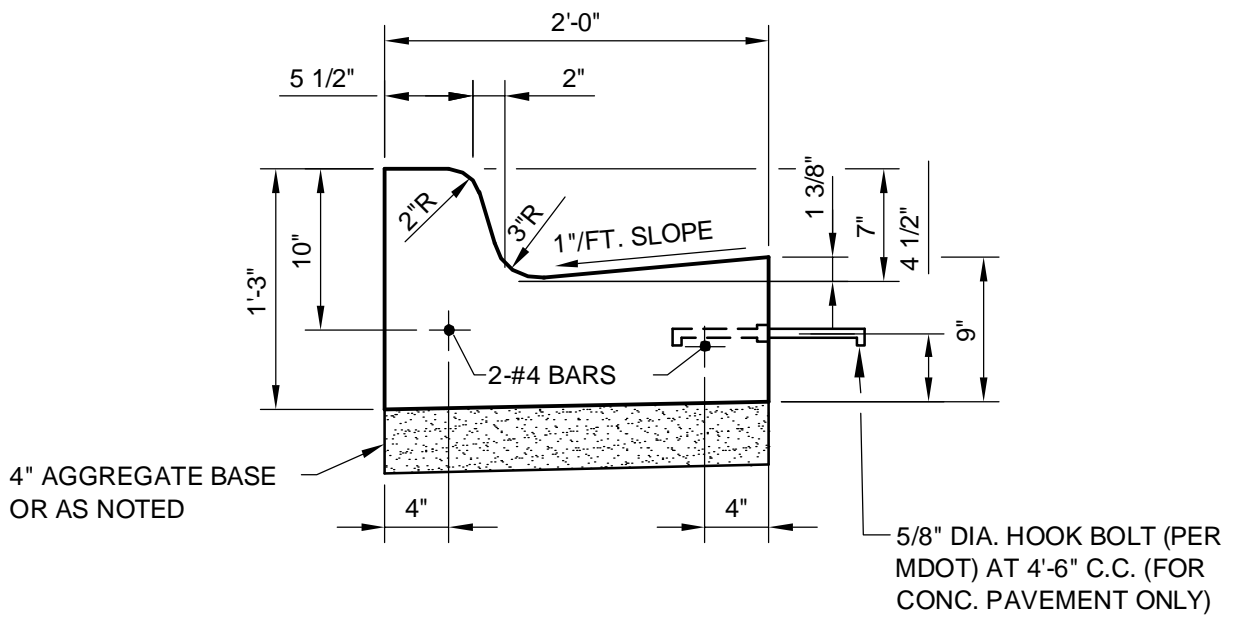

TYPE A
MDOT DETAIL R-30-E - TYPE C

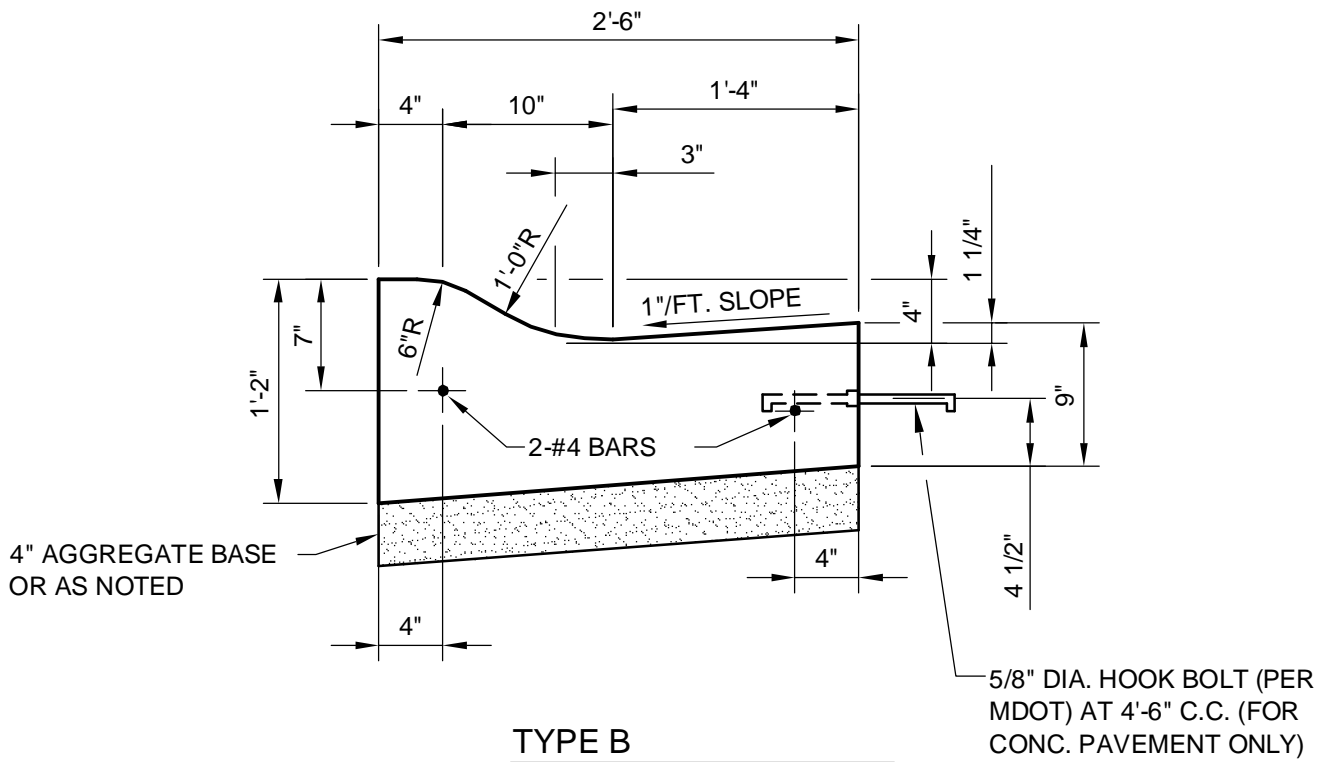

TYPE B
MDOT DETAIL R-30-E - TYPE D

Oceola Township

CONCRETE
CURB & GUTTER

Date: FEBRUARY 2010

G-1

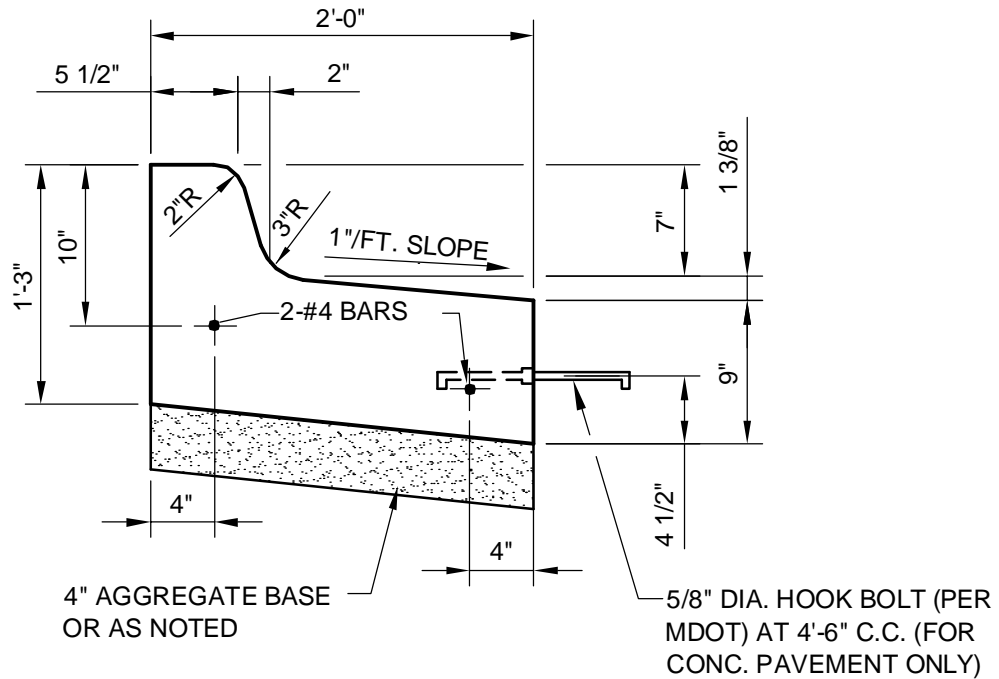

TYPE A1
MDOT DETAIL R-30-E - TYPE C - MODIFIED

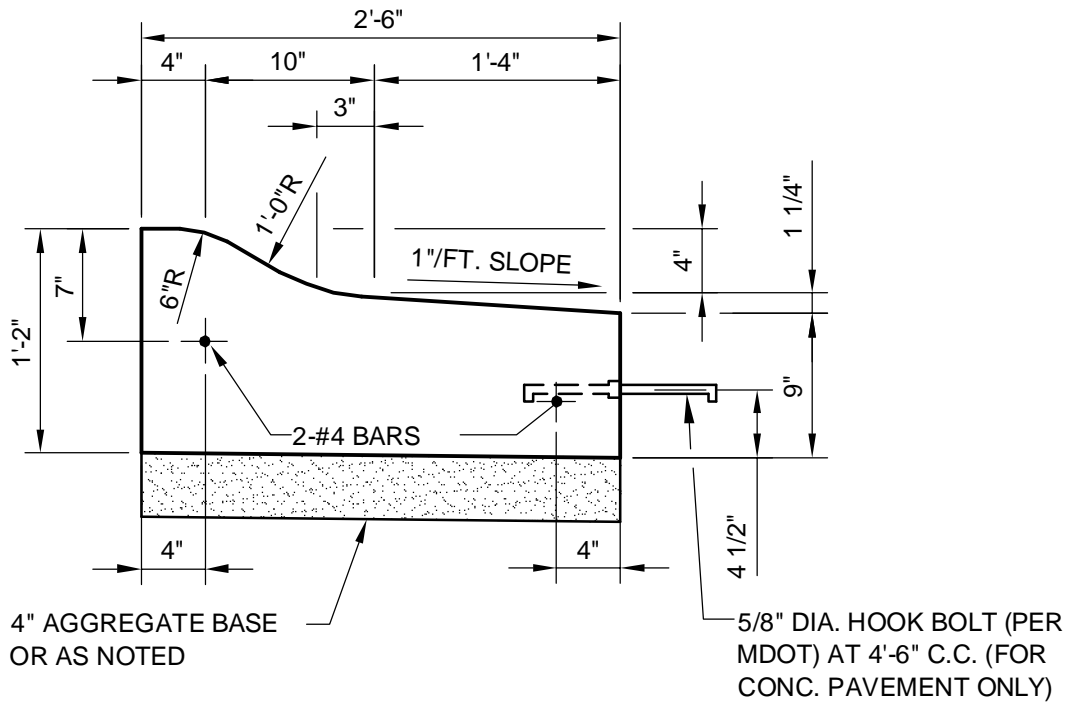

TYPE B1
MDOT DETAIL R-30-E - TYPE D - MODIFIED

Oceola Township

CONCRETE
CURB SPILLOUT

Date: FEBRUARY 2010

G-2

10 February 2010 DRAWING: P:\ER\12776\200-12776-00-000\SupportDocs\Std-Codes\Oceola Township Design Standards\February 2010\CAD\OCEOLA-STD .DWG

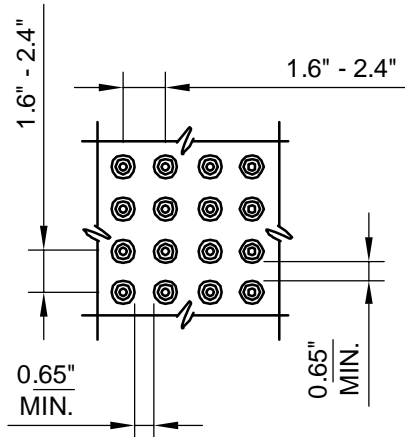
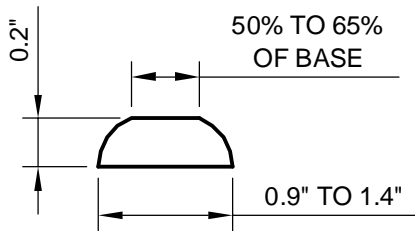
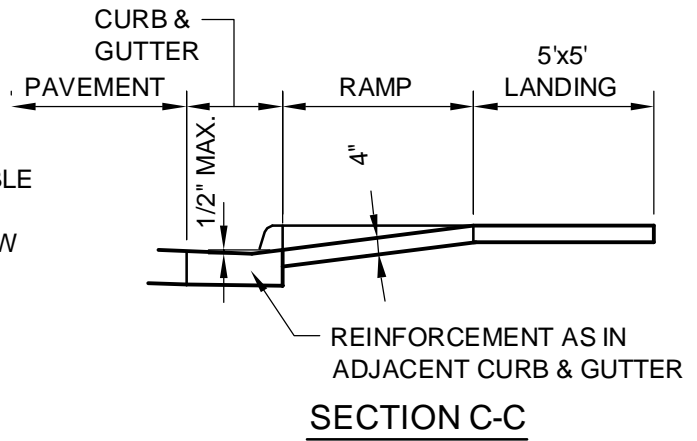
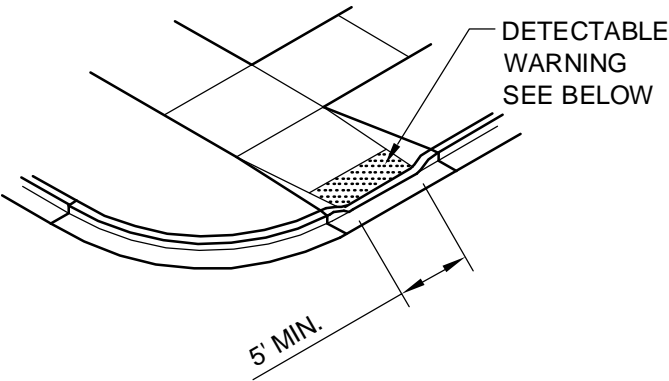
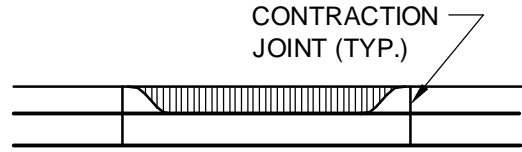
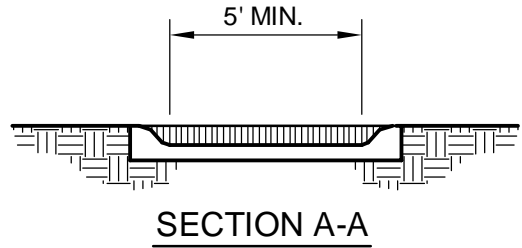
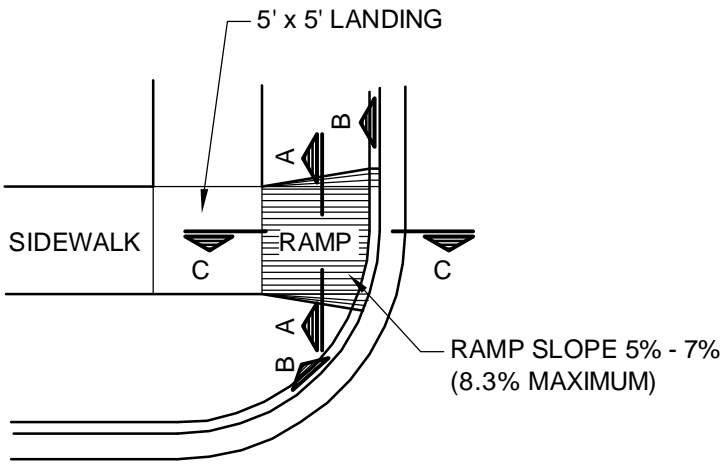

NOTE: SEE MDOT R-28-F SIDEWALK RAMP AND DETECTABLE WARNING DETAILS FOR ADDITIONAL INFORMATION.

Oceola Township

SIDEWALK RAMP

Date: FEBRUARY 2010

G-3

NOTE:
 MINIMUM ACCEPTABLE PAVEMENT STRUCTURE SHALL BE:
 1-1/2" BITUMINOUS WEARING COURSE MDOT MIX 36A
 1 1/2" BITUMINOUS LEVELING COURSE MDOT MIX 13A (USE 0.10 GAL/S.Y. BOND COAT BETWEEN COURSES)
 8" GRAVEL BASE MDOT SPEC 22A
 10" CLASS II SUBBASE (DEPENDING ON SOILS)
 PREPARED COMPACTED SUBBASE.

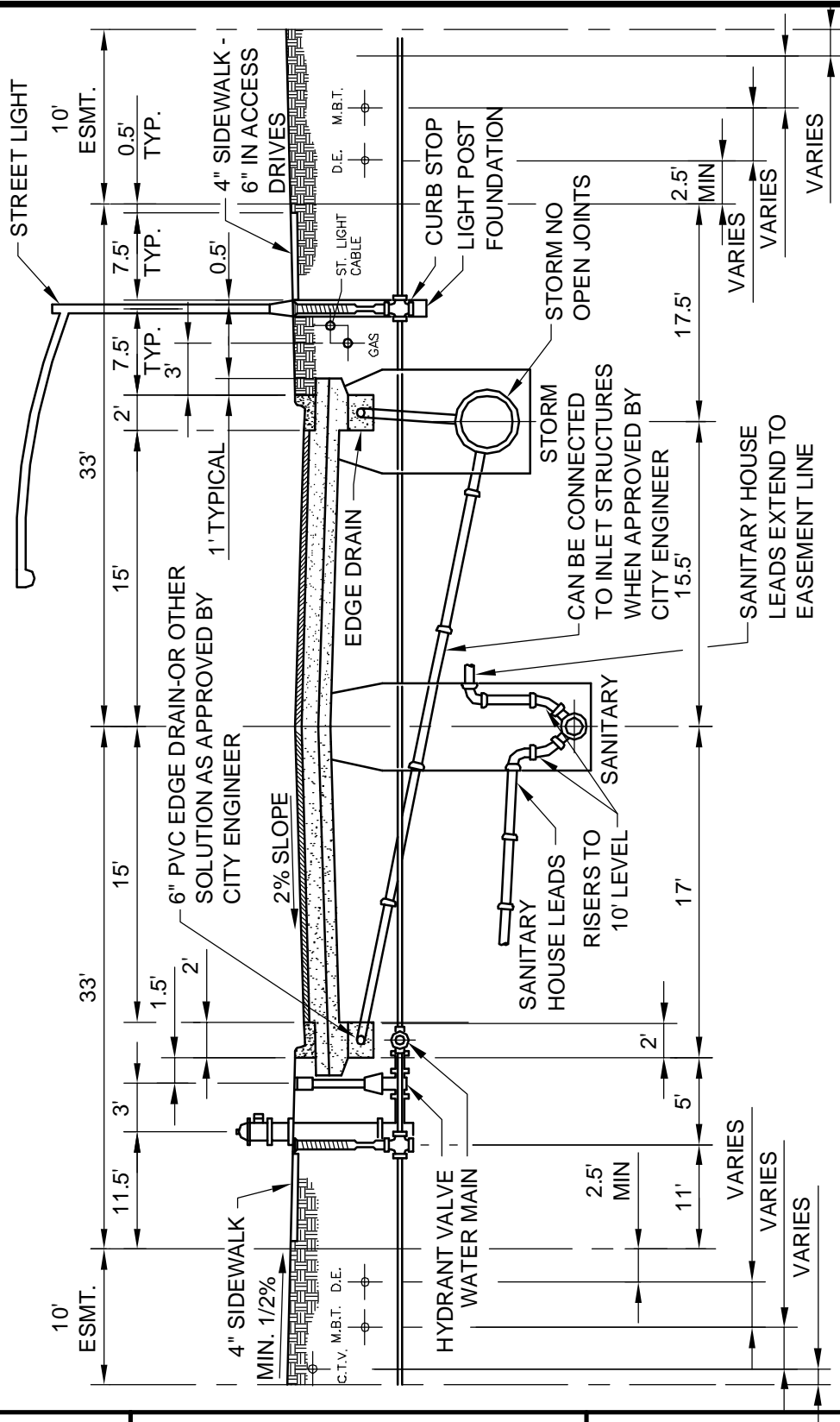

Oceola Township

**TYPICAL
 RESIDENTIAL STREET**

Date: FEBRUARY 2010

G-4

10 February 2010 DRAWING: P:\ER\12776\200-12776-00-000\SupportDocs\Standards-Codes\Oceola Township Design Standards\February 2010\CAD\OCEOLA-STD .DWG

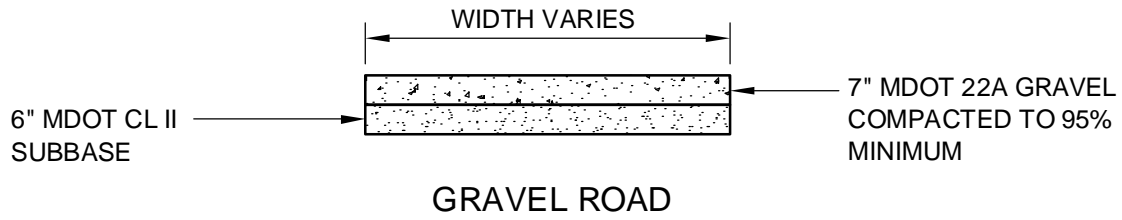
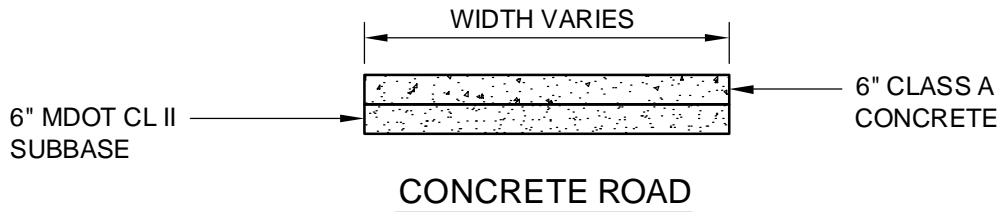
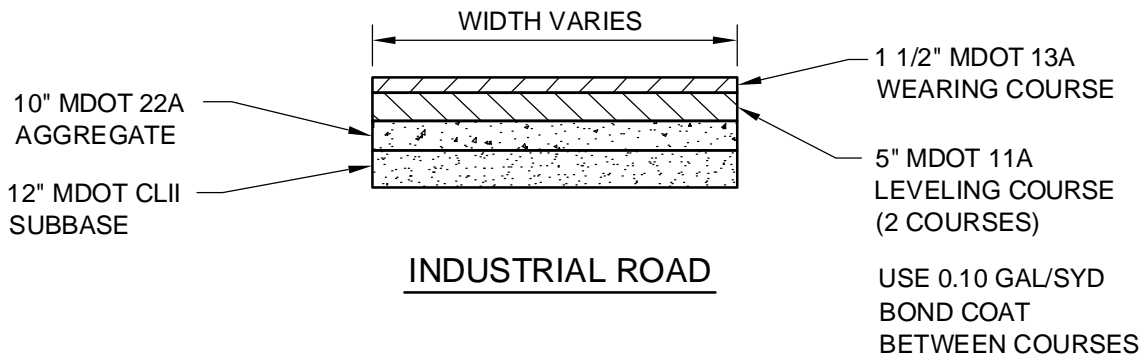
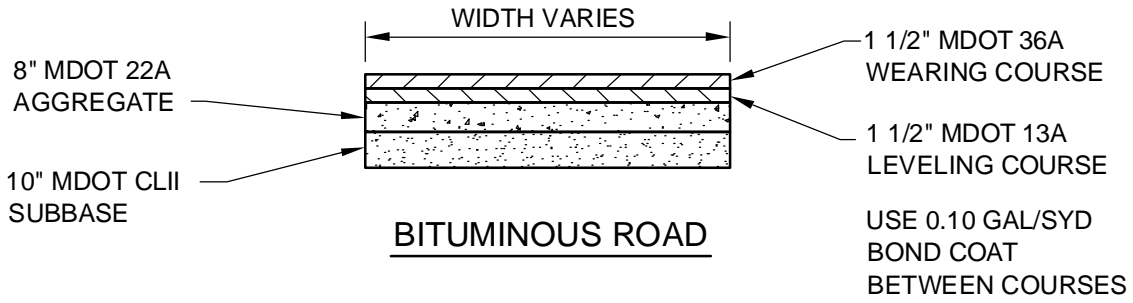

Oceola Township

ROADWAY
CROSS SECTIONS

Date: FEBRUARY 2010

G-5

10 February 2010 .DWG
 DRAWING: P:\VER\12776\200-12776-00-000\SupportDocs\Std-Codes\Oceola Township Design Standards\February 2010\CAD\OCEOLA-STD

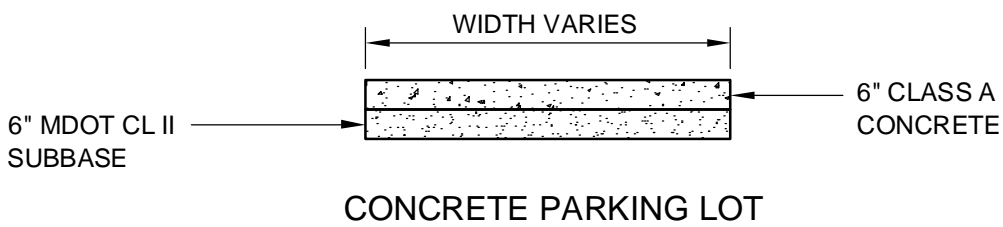
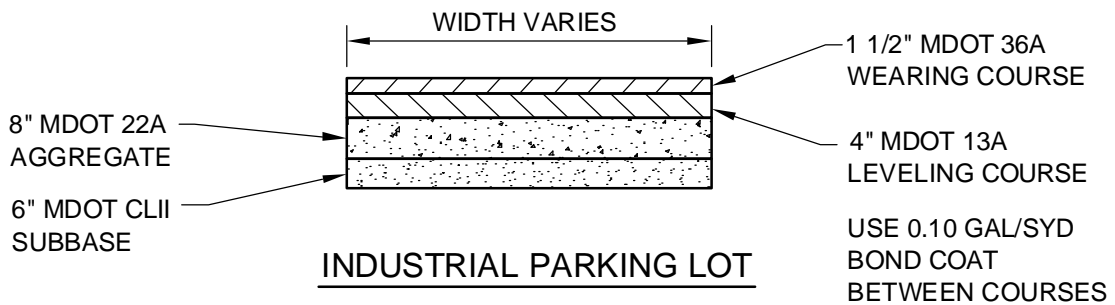
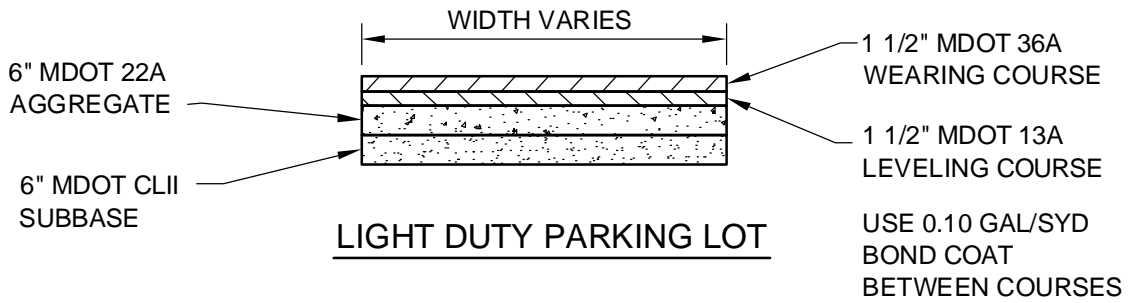

Oceola Township

PARKING LOT
CROSS SECTIONS

Date: FEBRUARY 2010

G-6

10 February 2010 DRAWING: P:\ER\12776\200-12776-00-000\SupportDocs\Std-Codes\Codes\Township Design Standards\February 2010\CAD\OCEOLA-STD .DWG

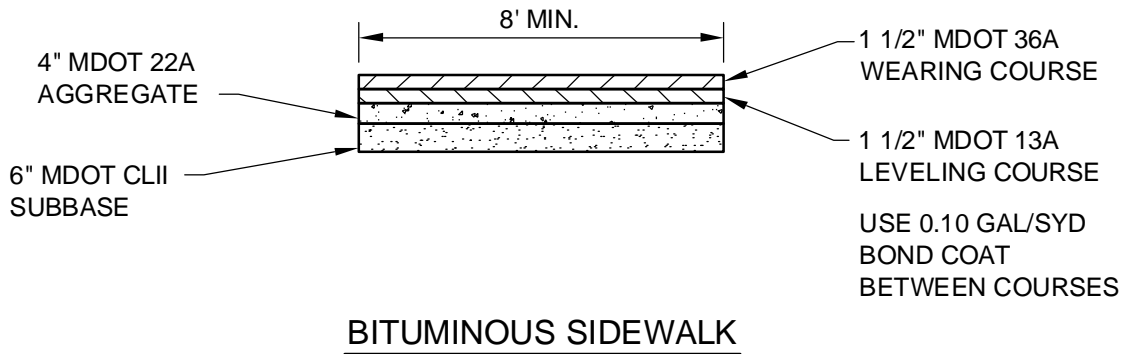
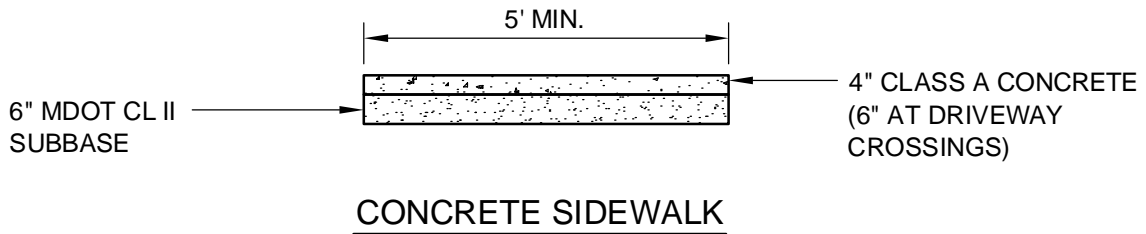

Oceola Township

TYPICAL
SIDEWALK
CROSS SECTIONS

Date: FEBRUARY 2010

G-7

SECTION 02240 - DEWATERING

PART 1 - GENERAL

1.01 SUMMARY

A. Section includes the following:

1. Dewatering consisting of performing work necessary to lower and control groundwater levels and hydrostatic pressures to permit excavation and construction to be performed in near-dry conditions.
 - a. Control of surface and subsurface water, ice, and snow are part of dewatering requirements.

PART 2 - PRODUCTS

NOT USED

PART 3 - EXECUTION

3.01 DEWATERING

- A. Provide an adequate system to lower and control groundwater in order to permit excavation, construction of structures, and placement of fill materials under dry conditions. Install sufficient dewatering equipment to pre-drain water-bearing strata above and below bottom of structure foundations, drains, sewers, and other excavations. The excavations shall be kept dry until exterior walls have been completed and until the structures have been backfilled. Drainage ditches shall not be placed within the area to be occupied by any structure except where permitted by ENGINEER. When such ditches are placed beneath the structures, they shall be backfilled with Class C concrete.
- B. Reduce hydrostatic head in water-bearing strata below structure foundations, drains, sewers, and other excavations to extent that water level and piezometric water levels in construction areas are below prevailing excavation surface.
- C. Prior to excavation below groundwater level, place system into operation to lower water levels as required and then operate it continuously 24 hours a day, 7 days a week until drains, sewers, and structures have been constructed, including placement of fill materials, and until dewatering is no longer required.
- D. Dispose of water removed from excavations in a manner to avoid endangering public health, property, and portions of Work under construction or completed. Dispose of water in a manner to avoid inconvenience to others engaged in work about Site. Provide sumps, sedimentation tanks, and other flow control devices as required by governing authorities. Effluent water from dewatering methods shall be sediment free or be discharged through an ENGINEER-approved sediment entrapment basin.
- E. Provide standby equipment on Site, installed and available for immediate operation if required to maintain dewatering on a continuous basis in event any part of system becomes inadequate or fails.

If dewatering requirements are not satisfied due to inadequacy or failure of dewatering system, perform work as may be required to restore damaged structures and foundation soils at no additional expense.

END OF SECTION

SECTION 02310 - EARTHWORK

PART 1 - GENERAL

1.01 SUMMARY

- A. Section includes the following:
 - 1. Preparing of subgrade for building slabs, walks, and pavements.
 - 2. Aggregate base courses for walks and pavements, aggregate surface courses, and aggregate shoulders.
 - 3. Drainage fill course for support of building slabs is included as part of this Work.
 - 4. Excavating and backfilling of trenches within building lines.
 - 5. Excavating and backfilling for underground mechanical and electrical utilities and buried mechanical and electrical appurtenances.
- B. Final Grading, placement, and preparation of topsoil for lawns, planting, and paving are specified in other Division 2 Sections.

1.02 DEFINITIONS

- A. Excavation consists of removal of material encountered to subgrade elevations indicated and subsequent disposal of materials removed.
- B. Unauthorized excavation consists of removal of materials beyond indicated subgrade elevations or dimensions without specific direction of ENGINEER. Unauthorized excavation, as well as remedial Work directed by ENGINEER, shall be at CONTRACTOR's expense.
 - 1. Under footings, foundation bases, or retaining walls, fill unauthorized excavation by extending indicated bottom elevation of footing or base to excavation bottom, without altering required top elevation. Lean concrete fill may be used to bring elevations to proper position when acceptable to ENGINEER.
 - 2. In locations other than those above, backfill and compact unauthorized excavations as specified for authorized excavations of same classification unless otherwise directed by ENGINEER.
- C. Additional Excavation: When excavation has reached required subgrade elevations, notify ENGINEER, who will make an inspection of conditions. If ENGINEER determines that bearing materials at required subgrade elevations are unsuitable, continue excavation until suitable bearing materials are encountered and replace excavated material as directed by ENGINEER. The Contract Price may be adjusted by an appropriate Contract Modification.
 - 1. Removal of unsuitable material and its replacement as directed will be paid on basis of Conditions of the Contract relative to changes in Work.
- D. Subgrade: The undisturbed earth or the compacted soil layer immediately below granular subbase, drainage fill, or topsoil materials.
- E. Subbase: The layer of specified materials of designed thickness placed to the subgrade as part of the pavement structure.
- F. Base Course: The layer or layers of specified or selected material of designed thickness placed on a subbase or a subgrade to support a surface course.

- G. Structure: Buildings, foundations, slabs, tanks, curbs, or other man-made stationary features occurring above or below ground surface.

1.03 SUBMITTALS

- A. Test Reports: Submit the following reports directly to ENGINEER from the testing services, with copy to CONTRACTOR:
 - 1. Test reports on borrow material.
 - 2. Verification of suitability of each footing subgrade material in accordance with specified requirements.
 - 3. Gradation analysis for subbase and base materials.
 - 4. Field reports; in-place soil density tests will be performed by a representative of OWNER.

1.04 QUALITY ASSURANCE

- A. Codes and Standards: Perform excavation Work in compliance with applicable requirements of authorities having jurisdiction. Construct subbase, base, and surface courses in accordance with the most recent edition of the Michigan Department of Transportation (MDOT) Standard Specifications for Construction.
- B. Testing and Inspection Service: OWNER will employ and pay for a qualified independent geotechnical testing and inspection laboratory to perform soil testing and inspection service during earthwork operations.

1.05 PROJECT CONDITIONS

- A. Existing Utilities: Locate existing underground utilities in areas of excavation Work. If utilities are indicated to remain in place, provide adequate means of support and protection during earthwork operations.
 - 1. Should uncharted, or incorrectly charted, piping or other utilities be encountered during excavation, consult utility Owner immediately for directions. Cooperate with OWNER and utility companies in keeping respective services and facilities in operation. Repair damaged utilities to satisfaction of utility Owner.
 - 2. Do not interrupt existing utilities serving facilities occupied by OWNER or others, during occupied hours, except when permitted in writing by ENGINEER, and then only after acceptable temporary utility services have been provided.
 - 3. Provide minimum of 48-hour notice to ENGINEER, and receive written notice to proceed before interrupting any utility.
 - 4. Demolish and completely remove from Site existing underground utilities indicated to be removed. Coordinate with utility companies for shutoff of services if lines are active.
- B. Use of Explosives: Use of explosives is not permitted.
- C. Protection of Persons and Property: Barricade open excavations occurring as part of this Work and post with warning lights.
 - 1. Operate warning lights as recommended by authorities having jurisdiction.
 - 2. Protect structures, utilities, sidewalks, pavements, and other facilities from damage caused by settlement, lateral movement, undermining, washout, and other hazards created by earthwork operations.

3. Perform excavation by hand within drip line of large trees to remain. Protect root systems from damage or dryout to the greatest extent possible. Maintain moist condition for root system and cover exposed roots with moistened burlap.

PART 2 - PRODUCTS

2.01 SOIL MATERIALS

- A. Satisfactory soil materials are defined as those complying with ASTM D 2487, Soil Classification Groups GW, GP, GM, SM, SW, and SP.
- B. Unsatisfactory soil materials are defined as those complying with ASTM D 2487, Soil Classification Groups GC, SC, ML, MH, CL, CH, OL, OH, and PT.
- C. Sand Bedding and Backfill: MDOT Specifications - Granular Materials Class III.
- D. Subbase Material: MDOT Specifications - Granular Materials Class II.
- E. Aggregate Base: Aggregate shall meet MDOT Specification 21AA or 22A.
- F. Drainage Fill: Washed, evenly graded mixture of crushed stone, or crushed or uncrushed gravel, with 100 percent passing a 1-1/2 inch sieve and not more than 5 percent passing a No. 4 sieve.
- G. Backfill and Fill Materials: Satisfactory soil materials free of clay, rock or gravel larger than 2 inches in any dimension, debris, waste, frozen materials, vegetation and other deleterious matter.
- H. Aggregate Surfaces and Shoulders: Surfaces on which no bituminous or concrete pavement is to be placed shall meet MDOT Specification 23A or 22A.
- I. Private Driveways: Surfaces on which no bituminous or concrete pavement is to be placed, and where no other material is specified, shall meet MDOT Specification 23A or 22A.

PART 3 - EXECUTION

3.01 EXCAVATION

- A. Excavation is unclassified and includes excavation to subgrade elevations indicated, regardless of character of materials and obstructions encountered.
- B. Excavation Classifications: The following classifications of excavation will be made when rock is encountered:
 1. Earth excavation includes excavation of pavements and other obstructions visible on surface; underground structures, utilities, and other items indicated to be demolished and removed; together with earth and other materials encountered that are not classified as rock or unauthorized excavation.
 2. Rock excavation for trenches and pits includes removal and disposal of materials and obstructions encountered that cannot be excavated with a track-mounted power excavator, rated at not less than 115 horsepower flywheel power and 32,000-pound drawbar pull and equipped

with a short stick and a 42-inch wide, short tip radius rock bucket rated at 0.81 cubic yard (heaped) capacity. Trenches in excess of 10 feet in width and pits in excess of 30 feet in either length or width are classified as open excavation.

3. Rock excavation in open excavations includes removal and disposal of materials and obstructions encountered that cannot be dislodged and excavated with modern, track-mounted, heavy-duty excavating equipment without drilling, blasting, or ripping. Rock excavation equipment is defined as rated at not less than 210 horsepower flywheel power and developing minimum of 45,000-pound breakout force (measured in accordance with SAE J732).
 - a. Typical of materials classified as rock are boulders 1/2 cubic yard or more in volume, solid rock, rock in ledges, and rock-hard cementitious aggregate deposits.
 - b. Intermittent drilling, blasting, or ripping performed to increase production and not necessary to permit excavation of material encountered will be classified as earth excavation.
- C. Do not perform rock excavation work until material to be excavated has been cross-sectioned and classified by ENGINEER. Such excavation will be paid on basis of Contract Conditions relative to changes in Work.
- D. Rock payment lines are limited to the following:
 1. Two feet outside of concrete work for which forms are required, except footings.
 2. One foot outside perimeter of footings.
 3. In pipe trenches, 6 inches below invert elevation of pipe and 2 feet wider than inside diameter of pipe, but not less than 3 feet minimum trench width.
 4. Outside dimensions of concrete work where no forms are required.
 5. Under slabs on grade, 6 inches below bottom of concrete slab.

3.02 STABILITY OF EXCAVATIONS

- A. Comply with local codes, ordinances, and requirements of agencies having jurisdiction.
- B. Slope sides of excavations to comply with local codes, ordinances, and requirements of agencies having jurisdiction. Shore and brace where sloping is not possible because of space restrictions or stability of material excavated. Maintain sides and slopes of excavations in safe condition until completion of backfilling.
- C. Shoring and Bracing: Provide materials for shoring and bracing, such as sheet piling, uprights, stringers, and cross braces, in good serviceable condition. Maintain shoring and bracing in excavations regardless of time period excavations will be open. Extend shoring and bracing as excavation progresses.
 1. Provide permanent steel sheet piling or pressure-creosoted timber sheet piling wherever subsequent removal of sheet piling might permit lateral movement of soil under adjacent structures. Cut off tops a minimum of 2'-6" below final grade and leave permanently in place.

3.03 DEWATERING

- A. Prevent surface water and subsurface or groundwater from flowing into excavations and from flooding Project Site and surrounding area or from impacting the subgrade.
 1. Do not allow water to accumulate in excavations. Remove water to prevent softening of foundation bottoms, undercutting footings, and soil changes detrimental to stability of subgrades and foundations. Provide and maintain pumps, well points, sumps, suction and

- discharge lines, and other dewatering system components necessary to convey water away from excavations.
2. Remove subsurface water below structure excavations until the water level is far enough below the subgrade elevation to allow the required subgrade compaction. Dewatering shall be completed before the subgrade is exposed and before ENGINEER inspects the subgrade condition. Place dewatering wells outside the load-bearing influence area of the structure foundation. Provide test pits, well points, piping, pumps, electrical power, and other equipment necessary for dewatering.
 3. Establish and maintain temporary drainage ditches and other diversions outside excavation limits to convey rainwater and water removed from excavations to collecting or runoff areas. Do not use trench excavations as temporary drainage ditches.

3.04 STORAGE OF EXCAVATED MATERIALS

- A. Stockpile excavated materials acceptable for backfill and fill where directed. Place, grade, and shape stockpiles for proper drainage.
 1. Locate and retain soil materials away from edge of excavations. Do not store within drip line of trees indicated to remain.
 2. Dispose of excess excavated soil material and materials not acceptable for use as backfill or fill.

3.05 EXCAVATION FOR STRUCTURES

- A. Conform to elevations and dimensions shown within a tolerance of plus or minus 0.10 foot, and extending a sufficient distance from footings and foundations to permit placing and removal of concrete formwork, installation of services, and other construction and for inspection.
 1. Excavations for Footings and Foundations: Do not disturb bottom of excavation. Excavate by hand to final grade just before concrete reinforcement is placed. Trim bottoms to required lines and grades to leave solid base to receive other work.
 2. For pile foundations, stop excavations from 6 to 12 inches above bottom of footing before piles are placed. After piles have been driven, remove loose and displaced material. Excavate to final grade, leaving solid base to receive concrete pile caps.
 3. Excavation for Underground Tanks, Basins, and Mechanical or Electrical Structures: Conform to elevations and dimensions indicated within a tolerance of plus or minus 0.10 foot; plus a sufficient distance to permit placing and removal of concrete formwork, installation of services, and other construction and for inspection. Do not disturb bottom of excavations, intended for bearing surface.

3.06 EXCAVATION FOR PAVEMENTS

- A. Cut surface under pavements to comply with cross-sections, elevations, and grades as indicated.

3.07 TRENCH EXCAVATION FOR PIPES AND CONDUIT

- A. Excavate trenches to uniform width, sufficiently wide to provide ample working room and a minimum of 6 to 9 inches of clearance on both sides of pipe or conduit.
- B. Excavate trenches for conduit to depth indicated or required to establish indicated slope and invert elevations and to support bottom of pipe or conduit on undisturbed soil. Beyond building perimeter, excavate trenches to allow installation of top of pipe below frost line or to elevations as shown on Drawings.

1. Where rock is encountered, carry excavation 6 inches below required elevation and backfill with a 6-inch layer of sand or pea gravel prior to installation of pipe.
2. For pipes or conduit less than 6 inches in nominal size, and for flat-bottomed, multiple-duct conduit units, do not excavate beyond indicated depths. Hand excavate bottom cut to accurate elevations and support pipe or conduit on undisturbed soil.
3. For pipes and equipment 6 inches or larger in nominal size, shape bottom of trench to fit bottom of pipe for 90 degrees (bottom 1/4 of the circumference). Where the subgrade is disturbed, fill depressions with tamped sand backfill. At each pipe joint, dig bell holes to relieve pipe bell of loads ensure continuous bearing of pipe barrel on bearing surface.

3.08 EXCAVATION FOR INFILTRATION BASINS

- A. Excavate the basin by removing the overburden to clean coarse sand and/or removing the overburden and balancing the coarse sand as shown on Drawings. The basin bottom shall be leveled to the elevation shown on Drawings. CONTRACTOR shall avoid compaction or disturbance of the infiltration basin surface during construction except as required to establish proposed grades. Prior to final acceptance, the surface shall be chisel plowed.
- B. Excavated soil which is removed from the excavation area shall not be deposited or stockpiled in any area which may result in washing of the soil into the basin bottom. In addition, erosion and sedimentation control shall be provided around the basin area to prevent soils from entering the excavated area. Any soils which are washed, blown, or deposited onto the basin bottom, shall be removed prior to final acceptance.
- C. Excess excavated material may be used to construct berms around the infiltration basins as shown on Drawings. Excess material not used as fill on the Site shall be disposed of as indicated on Drawings or shall be hauled off Site to a location determined by CONTRACTOR.
 1. There shall be no equipment storage in the basin area. Fueling of equipment must be done outside the basin area.
 2. Slopes of infiltration basin above basin bottom and all disturbed areas outside basin shall be seeded and grass shall be established as specified in other Division 2 Sections.

3.09 BACKFILL AND FILL

- A. Place and compact sand to a level 1 foot above the top of the pipe or conduit, then place soil material in layers to required subgrade elevations, for each area classification listed below, using materials specified in Part 2 of this Section.
 1. Under grassed areas, use satisfactory excavated or borrow material.
 2. Under walks and pavements, use subbase material, satisfactory excavated, or borrow material, or a combination.
 3. Under steps, use subbase material.
 4. Under building slabs, use drainage fill material.
 5. Under piping and conduit and equipment, use subbase materials where required over rock bearing surface and for correction of unauthorized excavation. Shape excavation bottom to fit bottom 90 degrees of cylinder.
 6. Backfill trenches with concrete where trench excavations pass within 18 inches of column or wall footings and that are carried below bottom of such footings or that pass under wall footings. Place concrete to level of bottom of adjacent footing.
 - a. Concrete is specified in Division 3.

- b. Do not backfill trenches until tests and inspections have been made and backfilling is authorized by ENGINEER. Use care in backfilling to avoid damage or displacement of pipe systems.
- B. Backfill excavations as promptly as Work permits, but not until completion of the following:
 - 1. Acceptance of construction below finish grade including, where applicable, dampproofing, waterproofing, and perimeter insulation.
 - 2. Inspection, testing, approval, and recording locations of underground utilities have been performed and recorded.
 - 3. Removal of concrete formwork.
 - 4. Removal of shoring and bracing, and backfilling of voids with satisfactory materials. Cut off temporary sheet piling driven below bottom of structures and remove in manner to prevent settlement of the structure or utilities, or leave in place if required.
 - 5. Removal of trash and debris from excavation.
 - 6. Permanent or temporary horizontal bracing is in place on horizontally supported walls.

3.10 PLACEMENT AND COMPACTION

- A. Ground Surface Preparation: Remove vegetation, debris, unsatisfactory soil materials, obstructions, and deleterious materials from ground surface prior to placement of fills. Plow strip, or break up sloped surfaces steeper than 1 vertical to 4 horizontal so that fill material will bond with existing surface.
 - 1. When existing ground surface has a density less than that specified in this Article for particular area classification, break up ground surface, pulverize, moisture-condition to optimum moisture content, and compact to required depth and percentage of maximum density.
- B. Place backfill and fill materials in layers not more than 8 inches in loose depth for material compacted by heavy compaction equipment, and not more than 4 inches in loose depth for material compacted by hand-operated tampers.
- C. Before compaction, moisten or aerate each layer as necessary to provide optimum moisture content. Compact each layer to required percentage of maximum dry density or relative dry density for each area classification. Do not place backfill or fill material on surfaces that are muddy, frozen, or contain frost or ice.
- D. Place backfill and fill materials evenly adjacent to structures, piping, or conduit to required elevations. Prevent wedging action of backfill against structures or displacement of piping or conduit by carrying material uniformly around structure, piping, or conduit to approximately same elevation in each lift.
- E. Control soil and fill compaction, providing minimum percentage of density specified for each area classification indicated below. Correct improperly compacted areas or lifts as directed by ENGINEER if soil density tests indicate inadequate compaction.
 - 1. Percentage of Maximum Density Requirements: Compact soil to not less than the following percentages of maximum density, in accordance with ASTM D 1557:
 - a. Under structures, building slabs and steps, and pavements, compact top 12 inches of subgrade and each layer of backfill or fill material at 95 percent maximum density.
 - b. Under lawn or unpaved areas, compact top 6 inches of subgrade and each layer of backfill or fill material at 90 percent maximum density.

- c. Under walkways, compact top 6 inches of subgrade and each layer of backfill or fill material at 95 percent maximum density.
- 2. Moisture Control: Where subgrade or layer of soil material must be moisture conditioned before compaction, uniformly apply water to surface of subgrade or layer of soil material. Apply water in minimum quantity as necessary to prevent free water from appearing on surface during or subsequent to compaction operations.
 - a. Remove and replace, or scarify and air dry, soil material that is too wet to permit compaction to specified density.
 - b. Stockpile or spread soil material that has been removed because it is too wet to permit compaction. Assist drying by discing, harrowing, or pulverizing until moisture content is reduced to a satisfactory value.

3.11 GRADING

- A. Uniformly grade areas within limits of grading under this Section, including adjacent transition areas. Smooth finished surface within specified tolerances, compact with uniform levels or slopes between points where elevations are indicated, or between such points and existing grades.
- B. Grading Outside Building Lines: Grade areas adjacent to building lines to drain away from structures and to prevent ponding. Finish surfaces free from irregular surface changes and as follows:
 - 1. Lawn or Unpaved Areas: Finish areas to receive topsoil to within not more than 0.10 foot above or below required subgrade elevations.
 - 2. Walks: Shape surface of areas under walks to line, grade and cross-section, with finish surface not more than 0.10 foot above or below required subgrade elevation.
 - 3. Pavements: Shape surface of areas under pavement to line, grade, and cross-section, with finish surface not more than 1/2 inch above or below required subgrade elevation.
- C. Grading Surface of Fill Under Building Slabs: Grade smooth and even, free of voids, compacted as specified, and to required elevation. Provide final grades within a tolerance of 1/2 inch when tested with a 10-foot straightedge.
- D. Compaction: After grading, compact subgrade surfaces to the depth and indicated percentage of maximum or relative density for each area classification.

3.12 PAVEMENT SUBBASE COURSE

- A. Subbase course consists of placing subbase material, in layers of specified thickness, over subgrade surface to support a pavement base course.
 - 1. Refer to other Division 2 Sections for paving specifications.
- B. Shoulders: Place shoulders along edges of subbase course to prevent lateral movement. Construct shoulders of acceptable soil materials, placed in such quantity to compact to thickness of each subbase course layer. Compact and roll at least a 12-inch width of shoulder simultaneous with the compaction and rolling of each layer of subbase course.
- C. Placing: Place subbase course material on prepared subgrade in layers of uniform thickness, conforming to indicated cross-section and thickness. Maintain optimum moisture content for compacting subbase material during placement operations.
 - 1. When a compacted subbase course is indicated to be 6 inches thick or less, place material in a single layer. When indicated to be more than 15 inches thick, place material in equal layers,

except no single layer more than 8 inches or less than 3 inches in thickness when compacted. Subgrade shall be compacted to 95 percent maximum density.

3.13 AGGREGATE BASE COURSE

- A. Aggregate base course consists of placing base materials of the type and thickness, over a prepared subgrade or subbase, as shown on Drawings.
- B. Placing: Aggregate base shall be placed in accordance with MDOT Specifications. Aggregate base shall be conditioned in accordance with Method No. 2.

3.14 AGGREGATE SURFACE COURSE

- A. Aggregate surface courses consist of constructing an aggregate surface on prepared subgrade or subbase, an aggregate base or an existing aggregate surface.
- B. Placing: Aggregate surface courses shall be constructed in accordance with MDOT Specifications.

3.15 AGGREGATE SHOULDERS

- A. Aggregate shoulders and approaches shall be constructed to the thickness and dimensions as shown on Drawings.
- B. Placing: Aggregate shoulders and approaches shall be constructed in accordance with MDOT Specifications for Class A shoulders.

3.16 BUILDING SLAB DRAINAGE COURSE

- A. Drainage course consists of placement of drainage fill material, in layers of indicated thickness, over subgrade surface to support concrete building slabs.
- B. Placing: Place drainage fill material on prepared subgrade in layers of uniform thickness, conforming to indicated cross-section and thickness. Maintain optimum moisture content for compacting material during placement operations.
 - 1. When a compacted drainage course is indicated to be 6 inches thick or less, place material in a single layer. When indicated to be more than 6 inches thick, place material in equal layers, except no single layer more than 6 inches or less than 3 inches in thickness when compacted.

3.17 FIELD QUALITY CONTROL

- A. Quality Control Testing during Construction: Allow testing service to inspect and approve each subgrade and fill layer before further backfill or construction work is performed.

3.18 EROSION CONTROL

- A. Provide erosion control methods in accordance with details shown on Drawings and/or requirements of authorities having jurisdiction.

3.19 MAINTENANCE

- A. Protection of Graded Areas: Protect newly graded areas from traffic and erosion. Keep free of trash and debris.
- B. Repair and reestablish grades in settled, eroded, and rutted areas to specified tolerances.
- C. Reconditioning Compacted Areas: Where completed compacted areas are disturbed by subsequent construction operations or adverse weather, scarify surface, reshape, and compact to required density prior to further construction.
- D. Settling: Where settling is measurable or observable at excavated areas during general Project warranty period, remove surface (pavement, lawn, or other finish), add backfill material, compact, and replace surface treatment. Restore appearance, quality, and condition of surface or finish to match adjacent work, and eliminate evidence of restoration to greatest extent possible.

3.20 DISPOSAL OF EXCESS AND WASTE MATERIALS

- A. Removal to Designated Areas on OWNER's Property: Transport acceptable excess excavated material to designated soil storage areas on OWNER's property. Stockpile soil or spread as directed by ENGINEER.
 - 1. Transport waste material, including unacceptable excavated material, trash, and debris to designated spoil areas on OWNER's property and dispose of as directed.
- B. Removal from OWNER's Property: Remove waste materials, including unacceptable excavated material, trash, and debris, and dispose of it off OWNER's property.
 - 1. Remove excess excavated material, trash, debris, and waste materials and dispose of it off OWNER's property.

END OF SECTION

SECTION 02315 - EXCAVATION AND BACKFILL (SEWERS AND WATER MAIN)

PART 1 - GENERAL

1.01 SUMMARY

- A. Section Includes: Excavation, trenching, complete and continual dewatering of excavation, sheeting, bracing and shoring of sides of excavation, backfilling around structures and over pipe lines, and disposal of excess excavated material.

1.02 REFERENCES

- A. Reference Standards:
 - 1. ASTM D 1557 Test Methods for Laboratory Compaction Characteristics of Soil Using Modified Effort (56,000 ft-lbf/ft³) - Modified Proctor Test.
 - 2. ASTM D 2487 Classification of Soils for Engineering Purposes.
 - 3. MDOT Michigan Department of Transportation, Standard Specifications for Construction, most recent edition.

1.03 DEFINITIONS

- A. Earth: Earth, as a name for excavated material, shall include all glacial deposit whether cemented or not, except solid boulders 1/2 cubic yard or more in volume. It shall include all alluvial deposits and material of every kind that can be excavated with equal facility by the equipment and means used for other earth excavation in Work.
- B. Rock: Rock, as a name for excavated material, shall include pre-glacial solid ledge rock that can be removed most practically by blasting, barring, or wedging, or by some other standard method of quarrying solid rock. It shall include solid boulders of 1/2 cubic yard or more in volume, existing concrete, masonry with mortar joints, or other existing structural work that can be excavated practically only by methods of quarrying solid rock. It shall not include fragile, friable, or disintegrated materials of any kind that can be excavated with equal facility by equipment and means used for earth excavation.
- C. Site-excavated Backfill: Site-excavated backfill shall be defined as site-excavated material, free from frozen earth, boulders, rocks, stones larger than 6 inches in size, debris, and organic material.
- D. Granular Fill: Granular fill shall be defined as sharp sand, gravel, or crushed stone, free from lumps of clay, soft or flaky material and shall conform to MDOT Specification, "Granular Materials - Class III."
- E. Subgrade: The undisturbed earth or the compacted soil layer immediately below granular subbase, drainage fill, or topsoil materials.
- F. Subbase: The layer of specified materials of designed thickness placed on the subgrade as part of the pavement structure.
- G. Structure: Buildings, foundations, slabs, tanks, curbs, or other man-made stationary features occurring above or below ground surface.

1.04 SUBMITTALS

- A. Test and Inspection Reports: Written reports shall be submitted to ENGINEER, with copy to CONTRACTOR, documenting testing and/or inspection results. The reports shall be prepared as noted under Section 01450. Tests shall include:
 - 1. Test reports on borrow material.
 - 2. Gradation analysis for granular backfill and subbase materials.
 - 3. Field reports; in-place soil density tests will be performed by a representative of OWNER.

1.05 QUALITY ASSURANCE

- A. Codes and Standards: Perform excavation work in compliance with applicable requirements of authorities having jurisdiction. Construct subbase in accordance MDOT Standard Specifications for Construction.

1.06 PROJECT CONDITIONS

- A. Existing Utilities: Locate existing underground utilities in areas of excavation work. If utilities are indicated to remain in place, provide adequate means of support and protection during earthwork operations.
- B. CONTRACTOR shall notify MISS-DIG, Utility Communications System, 1-800-482-7171, three working days prior to starting any excavation with power equipment.
 - 1. Should uncharted, or incorrectly charted, piping or other utilities be encountered during excavation, consult utility Owner immediately for directions. Cooperate with OWNER and utility companies in keeping respective services and facilities in operation. Repair damaged utilities to satisfaction of utility Owner.
 - 2. Do not interrupt existing utilities serving facilities occupied by OWNER or others during occupied hours except when permitted in writing by ENGINEER, and then only after acceptable temporary utility services have been provided.
 - 3. Provide minimum of 2 working days notice to ENGINEER and receive written notice to proceed before interrupting any utility.
 - 4. Demolish and completely remove from Site existing underground utilities indicated to be removed. Coordinate with utility companies for shutoff of services if lines are active.
- C. Use of Explosives: Use of explosives is not permitted.
- D. Protection of Persons and Property: Barricade open excavations occurring as part of this Work and post with warning lights.
 - 1. Operate warning lights as recommended by authorities having jurisdiction.
 - 2. Protect structures, utilities, sidewalks, pavements, and other facilities from damage caused by settlement, lateral movement, undermining, washout, and other hazards created by earthwork operations.
 - 3. Perform excavation by hand within drip line of large trees to remain. Protect root systems from damage or dryout to the greatest extent possible. Maintain moist condition for root system and cover exposed roots with moistened burlap.

PART 2 - PRODUCTS

2.01 SOIL MATERIALS

- A. Satisfactory soil materials are defined as those complying with ASTM D 2487 soil classification Groups GW, GP, GM, SM, SW, and SP.
- B. Unsatisfactory soil materials are defined as those complying with ASTM D 2487 soil classification Groups GC, SC, ML, MH, CL, CH, OL, OH, and PT.
- C. Bedding: MDOT Specification Granular Material 6A or Class I, except 100 percent must pass 1-1/2-inch sieve.
- D. Bedding for Thermoplastic Pipe, 6-inch Diameter or Less: Granular material with 100 percent passing the 1/2-inch sieve and less than 50 percent passing the No. 200 sieve.
- E. Granular Backfill: MDOT Specifications - Granular Materials Class III.
- F. Stone Refill: MDOT 6A Coarse Aggregate.
- G. Subbase Material: MDOT Specifications - Granular Materials Class II.
- H. Drainage Fill: Washed, evenly graded mixture of crushed stone, or crushed or uncrushed gravel, with 100 percent passing a 1-1/2-inch sieve and not more than 5 percent passing a No. 4 sieve.
- I. Backfill and Fill Materials: Satisfactory soil materials free of clay, rock, or gravel larger than 2 inches in any dimension, debris, waste, frozen materials, vegetation, and other deleterious matter.

PART 3 - EXECUTION

3.01 LIMITS OF EXCAVATION

- A. Trenches for pipes shall be excavated so that there shall be a minimum clearance of 6 inches on each side of the pipe barrel, and a maximum width at the level on the top of the pipe of not more than O.D. of the pipe, plus 12 inches on each side. Trenches shall be at all times of sufficient width to permit the pipe to be laid by first-class construction methods. Sufficient space shall be provided in the trench to permit the joints to be properly made. Before excavation is started in either bituminous or concrete paved streets, the paving shall be cut by means specified under this Section.
- B. The bottom of the trench in granular material shall be loosened to a depth of 4 inches below bottom of the pipe. Where the trench excavation for pipe is in rock, the trench bottom shall be undercut a minimum of 6 inches below the final location of the pipe and bedding material, herein specified, shall be placed and compacted along the haunch of the pipe.
- C. Excavation for structures shall be made to the outside lines and surfaces of such structures wherever it is practicable to build directly against the sides or bottoms of excavations. In such cases, care shall be taken not to disturb the original foundation or backing, with the final excavation or trimming being done by hand work just before the construction Work. If excess excavation is made, or the material becomes disturbed so as to require removal beyond the prescribed limits, the resulting space

shall be refilled with bedding, as specified in this Section, solidly machine tamped into place, to the required compaction, before construction work proceeds.

- D. Excavation for structures shall be extended sufficiently beyond the limits of the structure to provide ample room for form construction and other construction methods to be followed, wherever necessary.

3.02 LENGTH OF TRENCH OPENING

- A. In excavating for pipelines, the excavation shall at all times be finished to the required grade for an adequate distance in advance of the completed pipeline. Unless otherwise permitted by ENGINEER, not more than 50 feet of trench shall be open at one time in advance of the pipe. The length of the street which may be occupied by the construction work at any one time will be based on the requirements of use of the street by the public. No more than 600 consecutive feet of length of the street shall be occupied at one time, and vehicle traffic through the street shall not be entirely stopped without the permission of ENGINEER.

3.03 METHOD OF EXCAVATION IN EARTH

- A. All excavation shall be by open cut from the surface, except in special cases where tunneling under pavement or structures may be required or where tunneling under the root system shall be required for tree root protection. All excavation shall be made in such a manner and to such depth, length, and width as shall give ample room for building the structures, for bracing, sheeting, and supporting the sides of the excavation, for pumping and drainage of groundwater and sewage which may be encountered, and for the removal of all materials excavated. Special care shall be taken so that the soil below the bottom of structures to be built shall be left undisturbed to provide a firm bed for construction.

3.04 STABILITY OF EXCAVATIONS

- A. Comply with local codes, ordinances, and requirements of agencies having jurisdiction.
- B. Slope sides of excavations to comply with local codes, ordinances, and requirements of agencies having jurisdiction. Shore and brace where sloping is not possible because of space restrictions or stability of material excavated. Maintain sides and slopes of excavations in safe condition until completion of backfilling.

3.05 STORAGE OF EXCAVATED MATERIALS

- A. Stockpile excavated materials acceptable for backfill and fill where directed. Place, grade, and shape stockpiles for proper drainage.
 - 1. Locate and retain soil materials away from edge of excavations. Do not store within drip line of trees indicated to remain.
 - 2. Dispose of excess excavated soil material and materials not acceptable for use as backfill or fill.

3.06 BEDDING

- A. Place specified bedding materials under the pipe, in the haunches along the sides of the pipe, and over the pipe to a level 1 foot above the pipe. The material directly below the pipe shall be compacted. The material in the haunch area shall be placed in layers not to exceed 6 inches in depth,

and shall be compacted to 95 percent of its maximum unit weight. The material placed above the haunch area shall be compacted to percentage maximum unit weight as specified in this Section under "Compaction."

3.07 BACKFILLING TRENCHES

- A. All trenches in paved streets, shoulders, traveled roadways, parking areas, and driveways shall be backfilled with site-excavated backfill or granular fill, as shown on Drawings, from the level 1 foot above the top of the pipe to the specified road surface subgrade. The site-excavated backfill or granular fill shall be placed in not more than 6-inch layers and thoroughly and uniformly compacted by machine tamping to required compaction. With the approval of ENGINEER, water jetting on granular fill may be accepted in lieu of tamping in 6-inch layers.
- B. Trenches under concrete sidewalks shall be backfilled from a level 1 foot above the top of the pipe to a level 4 inches below the finished grade of the sidewalk with site-excavated backfill or granular fill and compacted to the required density.
- C. Trenches not in paved streets, shoulders, traveled roadways, parking areas, driveways, and under sidewalks shall be backfilled from a level 1 foot above the top of the pipe to the ground surface with site-excavated backfill and tamped as required to prevent trench settlement.
- D. Any depression resulting from settlement of the trench backfill previous to the date of total acceptance of all Work under this Contract shall be brought to proper grade and surface and made to match the adjacent surface.
- E. Wherever gas mains, water mains, sewers, etc., are located in the trench area, granular fill shall be used for backfill from the bottom of the trench up to the spring line of these pipes. Granular fill shall be placed full trench width with two horizontal to one vertical side slopes, and compacted in 6-inch layers to 95 percent of its maximum unit weight so as to thoroughly support the pipe within the trench area. Granular fill so required shall be considered included in the unit prices bid for other items of the Work. When directed by ENGINEER, dry mix Class "C" concrete shall be substituted for granular fill. The installation of any dry mix Class "C" concrete will be considered a Change in Work.

3.08 STONE REFILL

- A. In locations where the soil at the bottom of the trench is unstable, when ordered by ENGINEER, CONTRACTOR shall excavate below the trench bottom and replace excavated material with stone refill.

3.09 BACKFILLING AROUND STRUCTURES

- A. As soon as practical after concrete structures have set, forms and debris shall be removed and the surface of the concrete pointed. After the structure has been inspected and approved, the excavated area around the structure shall be backfilled up to the specified subgrade with granular fill or site-excavated backfill, as called for on Drawings for the adjacent trench. The fill shall be made in layers not to exceed 6 inches in depth and thoroughly compacted by machine tamping. No large boulders or masonry shall be placed in backfilling. No backfilling will be placed against manhole walls within 24 hours after the plaster coat has been applied to the outside of the walls, nor shall backfilling be

placed about concrete structures until the concrete has attained at least 75 percent of its design strength and approval of ENGINEER has been obtained.

3.10 CONCRETE CUTS

- A. When the trench must be cut through pavement, driveway, or sidewalk, particular care shall be taken not to unnecessarily damage the adjoining areas of pavement, driveway, or sidewalk. All cuts through existing surfaces shall be made with a concrete saw, sawing deep enough to allow a straight cut parallel to longitudinal or transverse construction or contraction joints.
- B. The saw cuts shall not be nearer than 5 feet to a transverse joint, to the centerline of the pavement, or to the edge of pavement or curb, i.e., no replacement shall be less than 5 feet in width. If the damaged pavement is nearer than 5 feet to a joint, to the centerline of pavement, or to the edge of pavement, surfacing or curb, the removal and replacement shall be extended to said joint, centerline, edge of pavement, surfacing or curb. These same requirements with reference to existing joints shall also apply to the cutting and replacement of concrete driveways.
- C. If a square or block of sidewalk is cut, broken or cracked, the entire block or square shall be removed and replaced.

3.11 CROSSING EXISTING STRUCTURES

- A. During construction, it may be necessary to cross under certain sewers, drains, culverts, water lines, gas lines, electric conduits, and other underground structures. Every effort shall be made to prevent damage to such underground structures. Wherever such structures are disturbed or broken, they shall be restored to good condition by CONTRACTOR unless otherwise noted on Drawings.

3.12 COMPACTION

- A. Percentage of Maximum Density Requirements: Compact soil to not less than the following percentages of maximum density, in accordance with ASTM D 1557:
 - 1. Under pavements, structures, and slabs, compact top 12 inches of subgrade and each layer of backfill or fill material at 95 percent maximum unit weight.
 - 2. Under lawn or unpaved areas, compact top 6 inches of subgrade and each layer of backfill or fill material at 90 percent maximum unit weight.
 - 3. Under walkways, compact top 6 inches of subgrade and each layer of backfill or fill material at 95 percent maximum unit weight.
- B. Moisture Control: Where subgrade or layer of soil material must be moisture-conditioned before compaction, uniformly apply water to surface of subgrade or layer of soil material. Apply water in minimum quantity as necessary to prevent free water from appearing on surface during or subsequent to compaction operations.
 - 1. Remove and replace, or scarify and air dry, soil material that is too wet to permit compaction to specified density.

3.13 DISPOSAL OF EXCAVATED MATERIAL

- A. Excavated material, where suitable, shall be used in backfilling around pipelines and structures. All material in excess of the quantity required for backfilling or unsuitable material shall be disposed of by CONTRACTOR. CONTRACTOR shall obtain such spoil sites as may be required, except that

ENGINEER may direct CONTRACTOR to dump materials at any site designated by OWNER within a 2-mile radius of Work area. CONTRACTOR shall provide all labor and equipment for spreading such material at the place of dumping, and shall leave the area in a neat condition satisfactory to ENGINEER.

3.14 TREE ROOT PROTECTION

- A. Machines shall freely excavate no closer to the base of a tree than the radius of the tree in inches converted to feet for trees less than 24 inches in diameter, and no closer than 12 feet if the tree is more than 24 inches in diameter. Tunneling under the root system will be required between the points so determined. Approaches closer than the previously stated distance, or tree removal, may be authorized by ENGINEER. Trees removed shall be disposed of at CONTRACTOR's expense.

3.15 ROADSIDE DITCHES AND CULVERTS

- A. All roadside ditches and driveway culverts shall be cleaned, repaired, and replaced to the same condition, or better, as existed before trenching operations commenced. Repair and/or replacement costs shall be included in other portions of the Work unless otherwise noted on Drawings.

3.16 FIELD QUALITY CONTROL

- A. Quality Control Testing during Construction: Allow testing service to inspect and approve each subgrade and fill layer before further backfill or construction work is performed.

3.17 EROSION CONTROL

- A. Provide erosion control methods in accordance with details shown on Drawings and/or requirements of authorities having jurisdiction.

3.18 MAINTENANCE

- A. Protection of Graded Areas: Protect newly graded areas from traffic and erosion. Keep free of trash and debris.
- B. Repair and reestablish grades in settled, eroded, and rutted areas to specified tolerances.
- C. Reconditioning Compacted Areas: Where completed compacted areas are disturbed by subsequent construction operations or adverse weather, scarify surface, reshape, and compact to required density prior to further construction.
- D. Settling: Where settling is measurable or observable at excavated areas during general Project warranty period, remove surface (pavement, lawn, or other finish), add backfill material, compact, and replace surface treatment. Restore appearance, quality, and condition of surface or finish to match adjacent work, and eliminate evidence of restoration to greatest extent possible.

END OF SECTION

SECTION 02630 - SEWERS

PART 1 - GENERAL

1.01 SUMMARY

- A. Section Includes: Labor, materials, and equipment necessary for furnishing the fabrication, production, installation, or erection of the items specified in this Section.

Excavation, trenching, and complete and continual dewatering of excavation; sheeting, bracing, or shoring of sides of excavation; furnishing and installing of the pipe and bedding; backfilling; placing, and maintaining temporary roadway surfaces over trenches in streets, drives, and parking areas; testing; and disposal of excess excavated materials are not detailed in this Section.

B. SUBMITTALS

- C. Shop Drawings: Submit Shop Drawings covering the items included under this Section. Shop Drawing submittals shall include:

1. Design details of the joint before ordering any pipe.
2. Boring and jacking methods of construction prior to performing any boring and jacking operation.
3. Pressure grout design mix.

- D. Quality Control Submittals: All pipe delivered to Site shall be accompanied by certification papers showing that the pipe has been tested in accordance with applicable Specifications and that the pipe meets these Specifications.

- E. Test and Inspection Report: A written report shall be submitted to ENGINEER documenting testing and/or inspection results.

1. The requirements for the necessary Infiltration/Exfiltration Tests are found in detail under "Laying Pipe" Article.

PART 2 - PRODUCTS

2.01 MANUFACTURERS

- A. Subject to compliance with specified requirements, manufacturers offering products which may be incorporated in Work include:

1. Pipe Joints, Ductile Iron:
 - a. Tyton.
 - b. Bell Tite.
 - c. Fast Tite.
2. Caulking Compound and Cold Mastic Compound:
 - a. "Sewertite," Philip Carey Mfg. Co.
 - b. "No. 10-WM," DeWitt Product Co.
3. Connections, Couplings:
 - a. Logan LCP Coupling.
 - b. Fernco, Series 1001-66.

2.02 SEWER PIPE

- A. Locations of various types of pipe are shown on Drawings. Sanitary sewer pipe shall be designed for air testing.
- B. Sewer pipe and fittings used in this Work shall meet requirements of referenced standard specifications. Sewer piping shall be of following types as noted on Drawings.
 - 1. Reinforced Concrete Sewer Pipe (RCSP): ASTM C 76, class as designated on Drawings or special design conforming to ASTM C 655.
 - 2. Concrete Sewer Pipe (CSP): ASTM C 14, Class III.
 - 3. Reinforced Concrete Elliptical Pipe (RCEP): ASTM C 507; VE or HE Class as designated on Drawings.
 - 4. Reinforced Concrete Pressure Pipe (RCPP): AWWA C 300, C 301 or C 302; Class as designated on Drawings.
 - 5. Polyvinyl Chloride Gravity Pipe (PVC): ASTM D 3034 or ASTM D 679, SDR 35 or SDR 26; ASTM D 2680, PVC truss pipe; ASTM F 949 PVC profile wall pipe (Contech A-2000). PVC compounds to meet ASTM D 1784, Cell Class 12454B or C.
 - 6. Polyvinyl Chloride Gravity Pipe (PVC): ASTM F 1803 PVC profile wall pipe (Lamson "Vylon Pipe"). PVC compounds to meet ASTM D 1784, Cell Class 12364A.
 - 7. Polyvinyl Chloride Pressure Pipe (PVCP): ASTM D 2241, SDR 26; ASTM D 2672; AWWA C900; AWWA C905; UNI-B-11. PVC compounds, ASTM D 1784 with Cell Class 12454 B or C.
 - 8. Polyvinyl Chloride Pipe (PVC) and Fittings: ASTM D 1785, Schedules 40, 80, and 120; ASTM D 2466; ASTM D 2467; ASTM D 3036; PVC compounds to meet ASTM D 1784, Cell Class 12454B or C.
 - 9. ABS or PVC Truss Pipe: ASTM D 2680. Joints to meet requirements of ASTM D 3212 with gaskets conforming to ASTM F 477.
 - 10. ABS Solid Plastic Pipe: ASTM D 2751, SDR 23.5.
 - 11. Solid Wall High-Density Polyethylene Pipe (HDPE): ASTM F 714 with minimum SDR of 32.5. Cell Classification shall be PE 345434C per ASTM D 3350.
 - 12. Ductile Iron Pipe (DIP) (cement lined, standard thickness): ANSI A 21.4, A 21.10, A 21.11, A 21.50, A 21.51; Class thickness as designated on Drawings.
 - 13. Corrugated Metal Pipe (CMP): AASHTO M 36 galvanized or M 190 bituminous coated with paved invert. AASHTO A 167 for field-assembled galvanized plates. Gauge as specified on Drawings.
 - 14. Corrugated Plastic Tubing (CPT): AASHTO M 252; ASTM F 405 for polyethylene and ASTM F 800 for polyvinyl chloride. Heavy-duty tubing with stiffness at 5 percent deflection of 30 psi and at 10 percent deflection of 25 psi. Polyethylene tubing 8-inch and greater shall meet requirements of ASTM F 667.
 - 15. Perforated Corrugated Plastic Tubing (PCPT): AASHTO M 252, ASTM F 405 for polyethylene, ASTM F 800 for polyvinyl chloride, and AASHTO M 36. Heavy-duty tubing with stiffness at 5 percent deflection of 30 psi and at 10 percent deflection of 25 psi. Perforation shall conform to requirements of AASHTO M 252.
 - 16. Perforated Corrugated PVC Pipe (PCPP): ASTM F 949. Pipe with stiffness at 5 percent deflection of 46 psi. Perforation shall conform to requirements of ASTM F 949.
 - 17. Perforated Corrugated Metal Pipe (PCMP): AASHTO M 36 galvanized. Thickness 6- to 10-inch pipe, 0.052 inch, and 12- to 21-inch pipe, 0.064 inch.

2.03 CULVERT PIPE

A. Corrugated Metal Pipe Culverts (CMPC): All culvert pipe shall be equal to the standard specifications for corrugated metal pipe culverts, AASHTO M 36. Pipe shall be galvanized. Unless otherwise noted on Drawings, the minimum gauge for corrugated metal pipe shall be:

1. Roadway:

<u>Pipe Diameter</u>	<u>Gauge</u>
8 - 18-inch	16
24 - 36-inch	14
42 - 48-inch	12
54 and larger	10

2. Railroad:

<u>Pipe Diameter</u>	<u>Gauge</u>
8 - 15-inch	14
18 - 21-inch	12
24 - 30-inch	10
36-inch and larger	8

B. End sections shall have all materials galvanized and coated as the culvert pipe. End sections shall be complete including coupling and necessary bolts. Corrugated metal end sections shall meet the requirements and Standard Plan IV-88A.

C. Concrete Pipe Culverts:

1. Concrete Sewer Pipe Culvert (CSPC) ASTM C 14, Table 3.
2. Reinforced Concrete Sewer Pipe Culverts (RCSPC) ASTM C 76, Class as designated on Drawings or special design conforming to ASTM C 655. Box culverts conforming to ASTM C 789 or C 850 as conditions allow.
3. Reinforced Concrete Arch or Elliptical Pipe Culverts (RCEPC) ASTM C 506 or C 507, VE or HE, Class as designated on Drawings.
4. Concrete end sections shall conform to MDOT Specification 8.08.19 and MDOT Standard Plan IV-86A.

2.04 PIPE JOINTS

A. Concrete or Reinforced Concrete Pipe:

1. Storm Sewers and Culverts:

- a. For joints in concrete or reinforced concrete pipe for storm sewers or culverts, provide bell and spigot or tongue and groove pipe with compression-type rubber gasket.
- b. Lubricant shall be supplied by pipe manufacturer, and the joint shall be made in accordance with manufacturer's instructions.
- c. Rubber gaskets shall meet physical properties requirements of ASTM C 443.
- d. Make joints in nonround reinforced concrete sewer pipe for which rubber gaskets are unavailable with caulking compound, flexible butyl rubber sealant or external bands conforming to ASTM C 877.
- e. Butyl rubber sealant shall meet AASHTO M 198.

2. Jacked Pipe:

- a. Joints in reinforced concrete pipe to be jacked-in-place shall be with compression-type rubber gasket or with tongue and groove, jointed with cold mastic and inside tuck-pointing. Place cushioning material, similar to celotex or hardboard, in joint shoulder between the pipe sections to distribute jacking pressures uniformly.

- b. After jacking operation is complete, point joints in pipe 30 inches and larger on inside by removing existing materials to depth of 3/4 inch and cementing this space by pointing with cement mortar, composed of 1 part of cement and 2 parts sand.
- B. Polyvinyl Chloride Pipe:
1. Joints in polyvinyl chloride pipe shall be bell and spigot type unless solvent weld joints are specified. Bell and spigot joints shall consist of spigot and formed bell complete with a factory installed flexible elastomeric gasket meeting ASTM F 477.
 2. Joints for pressure pipe (PVCP) shall conform to ASTM D 3139. Joints for nonpressure pipe (PVC) shall conform to ASTM D 3212. Solvent weld joints shall conform to ASTM D 2855.
 3. Joints in tee branches, wyes, fittings, riser pipes, and service laterals shall be similar to (including pressure rating) and compatible with joints furnished for sewer pipe. Joints shall be made using lubricant as recommended by pipe manufacturer. When necessary to field cut standard length of pipe, the new spigot end shall be prepared as recommended by pipe manufacturer.
 4. Joints in Schedule 40, 80, or 120 pipe shall be solvent weld according to ASTM D 2564 and D 2855.
- C. ABS Truss Pipe:
1. Provide sleeve-coupling Type "SC" chemically welded joint in ABS truss pipe as specified in ASTM D 2680.
 2. Fully and thoroughly coat exposed ends of ABS Truss Pipe with plastic jointing cement prior to making joints so as to seal ends to eliminate possibility of false low-pressure air tests. Take care to ensure joints are pushed to full "home" position and held tightly in "home" position during grade or line adjustments. Rotate pipe during joint insertion to ensure complete spread of jointing cement.
 3. Provide ABS Plastic Cement Primer and ABS Plastic Pipe Cement in sealed and labeled containers. Use "Johnny Mops" or similar swab type applicators to apply primer and cement. Protect opened containers in trench from dirt, water, and other contaminants.
- D. PVC Truss and Profile Wall Pipe Joints: Bell and spigot with a flexible elastomeric gasket meeting ASTM F 477. Assembled joint shall meet the requirements of ASTM D 3212. Lubricant for gasketed truss pipe shall be according to pipe manufacturer's recommendations.
- E. High-Density Polyethylene Pipe: Provide thermally butt-fused joints. Butt fusion equipment and the service of a qualified equipment operator shall be provided by pipe manufacturer to connect pipe segments, or manufacturer shall certify installer in the butt fusion process.
- F. Ductile Iron Pipe: Joints for ductile iron pipe shall conform to ANSI A 21.11 and shall be made in accordance with manufacturer's directions using rubber gaskets. Joints between ductile iron pipe and concrete or clay pipe shall be made using a rubber adapter.
- G. Corrugated Pipe:
1. Joints in corrugated pipe shall be made with bands having same gauge as pipe. Bands shall extend at least 2 corrugations on each side of joint and shall be corrugated-coupling type with O-ring rubber gasket. Rubber gasket shall meet physical properties requirements of ASTM C 443. Joint materials shall be galvanized and bituminous coated.
 2. Joints in corrugated pipe shall meet current MDOT Standards for storm sewer, and bands shall have same gauge as pipe. A spiral type band shall be used for joining new CMP to new CMP. All other couplings shall require approval by ENGINEER.

2.05 FLOWABLE FILL CONCRETE GROUT

- A. Flowable fill shall be a mixture of Portland cement thoroughly mixed with mortar sand and fly ash, as permitted by ENGINEER, with sufficient water to permit steady flow through grout pipes. The mix shall be 2 parts of sand to 1 part of cement, or an alternate mix with minimum compressive strength of 300 psi, to be approved by ENGINEER. Proportions may be varied at ENGINEER's order even to extent of enriching mix to neat cement. If necessary to speed up setting of grout, use approved admixtures of quick-setting cement as directed by ENGINEER.

PART 3 - EXECUTION

3.01 STORING FLEXIBLE PIPE

- A. After delivery, flexible pipe shall be stored on flat surface so that barrel is evenly supported. Pipe shall not be stored in piles higher than 4 feet. If pipe is to be stored for over 1 month, it shall be covered with opaque material so that it is protected from sun's rays; and bells shall be inverted in alternate rows so they are not supporting direct load. Deflection of pipe shall not exceed 5 percent. Follow manufacturer's instructions in storing and handling pipe during periods of temperature extremes.

3.02 DISPOSAL OF WATER AND SEWAGE

- A. CONTRACTOR shall remove by well points, pumping, bailing, or other acceptable method any water which may accumulate or be found in the trenches or other excavations to be made. CONTRACTOR shall make all necessary provisions to keep the trenches and other excavations entirely free of water during construction of pipelines and structures. Newly laid concrete shall be adequately protected from injury resulting from groundwater or sewage or from the handling or disposal of water or sewage. No drainage ditches shall be placed within the area to be occupied by any structure except as permitted by ENGINEER.
- B. CONTRACTOR shall at all times have upon the Site sufficient pumping equipment ready for immediate use to carry out the intent of this Section. All cost for dewatering trenches shall be incidental to the Contract.
- C. Additional requirements for dewatering are specified in Section 02240 - Dewatering.

3.03 DIVERTING EXISTING SEWERS

- A. Where existing sewers or drains are encountered in Work, adequate provision shall be made for diverting the flow in the existing sewers so that the excavation will be kept dry during the progress of the construction Work. Upon completion of the construction Work, the existing sewers shall be restored or otherwise provided with an adequate outlet as directed by ENGINEER.

3.04 CROSSING EXISTING STRUCTURES

- A. During construction, it may be necessary to cross under certain sewers, drains, culverts, water lines, gas lines, electric conduits, and other underground structures. Every effort shall be made to prevent damage to such underground structures. Wherever such structures are disturbed or broken, they shall be restored to good condition by CONTRACTOR unless otherwise noted on Drawings.

3.05 LAYING PIPE

- A. Pipe shall be laid from downstream to upstream, starting at the most downstream end of a run, unless approved by ENGINEER.
- B. Lay pipe with bells upgrade and to line and grade called for on Drawings. Finished sewer shall be straight and free of dirt or debris between manholes.
- C. Inspect each pipe for defects prior to being lowered into trench. Clean inside of pipe and outside of tongue and grooves of dirt or foreign matter. Place joint materials as recommended by manufacturer.
- D. Center pipe in grooves and push tight together to form smooth and continuous invert. Use mechanical means for pulling pipe home in making up joint and for holding pipe joints tight until completion of line. Mechanical means shall consist of a cable placed inside of pipe with a suitable winch, jack, or come-along for pulling pipe home and holding pipe in position.
- E. Use laser-aligning equipment for laying of sewers to specified lines and grades. Furnish equipment and personnel required to operate laser equipment.
 - 1. Rigidly mount laser beam projection to its support platforms in a manner approved by ENGINEER. This will ensure that ground equipment vibrations will be kept to minimum and will permit laser beam to be projected coaxially through center of pipe. Furnish units with equipment to control atmospheric conditions in pipe which could affect construction.
- F. ENGINEER will establish centerline stakes and offset stakes at each manhole and other centerline and offset stake as required for check points.
- G. Check short culverts not aligned by laser with grade pole and visual sighting through culvert to ensure straightness.
- H. Provide openings in pipe, as required for installation of laser equipment, at no additional cost to OWNER. Details of these openings will be approved by ENGINEER.
- I. After pipe is laid, carefully compact bedding under the haunches of pipe, and backfill trench to 12 inches above pipe. Place sufficient backfill after each joint is made along sides of pipe to offset conditions that might tend to move pipe off line and grade. Relay pipe found off grade or out of line.
- J. Regrade and channel ditch adjacent to culverts to provide unrestricted flow of surface water to the culvert.
- K. Allowable Tolerances in Sewer Grade: Construct and lay sewers to alignment and grade shown on Drawings or designated by ENGINEER. A variation greater than 1/4 inch from plan or designated grade is sufficient reason for rejection of sewer; and sewer shall be re-laid to proper grade if so directed by ENGINEER, at no cost to OWNER.

3.07 SEWER JACKED-IN-PLACE

- A. Pipe jacked-in-place under this Work shall be considered sewer or carrier pipe without casing pipe. Locate pipe to be jacked-in-place as shown on Drawings. Reinforcing steel for concrete pipe jacked-in-place shall be circular.
- B. Submit method of boring to ENGINEER for approval prior to construction.

3.08 JACKING PIPE

- A. Maintain groundwater table to level 2 feet below invert of pipe throughout the reach prior to and during jacking.
- B. Apply jacking pressure by pushing frame at right angles to line to avoid breaking pipe or forcing it out of alignment. Equip first section of pipe with a steel cutting shield placed over its circumference and securely bolt to pipe. Excavate ahead of pipe manually or by boring from inside of pipe.
- C. When excavating, keep voids outside of pipe and disturbances of surrounding material to a minimum. Fill excessive voids immediately with sand or other suitable material and thoroughly compact.
- D. Jack continuously insofar as possible to prevent seizure of pipe. However, if operation is discontinued, safely support with wood bulkhead and adequately block excavation.
- E. Fill void spaces between pipe and ground by pressure grouting. Provide ENGINEER with grout design mix for approval.
- F. Keep grouting pressure sufficiently high to fill all voids. Install necessary grouting holes at a maximum of 10 feet apart and as required to ensure complete filling of void spaces. Insert and securely caulk to the grout hole. Grout pipe at least 2 inches in diameter with control valve attached.
- G. Following satisfactory pipe grouting operations, remove grout pipe from grout hole after grout has taken its initial set. Completely fill space occupied by grout pipe with stiff mortar and trowel smooth at the inner face.

3.09 SHAFTS AND JACKING PITS

- A. Provide, construct, maintain, and refill shafts or jacking pits. Remove other temporary structures and construction and equipment upon completion of jacking.
- B. Completely sheet each jacking shaft to provide proper support for banks and adequate support for reaction blocks. Construct shaft long enough to provide room for jacking head frame, reaction blocks and two sections of pipe. Provide width sufficient to allow ample working room. Place backstops or reaction blocks absolutely perpendicular in all directions to axis of pipe and install guide timbers carefully to proper line and grade.
- C. Provide ladderways of steel construction in each shaft meeting State and Federal OSHA requirements.

3.11 CONCRETE CRADLE FOR PIPE

- A. Where called for on Drawings, install pipe with concrete cradle of Class "C" concrete.
- B. Rest each pipe on 6-inch-minimum thickness bed of dry mix concrete, shaped to fit bottom of pipe. Dry mix concrete shall be machine mixed Class "C" concrete described in Specification Section 03315. After setting pipe, fill space between outside of pipe and undisturbed trench bank to a level equal to a point 1/3 of diameter above pipe invert with Class "C" concrete, having a 2-inch slump. Mechanically vibrate concrete to ensure complete filling of annular space between excavated face of original ground and outside face of pipe.
- C. All concrete Work shall be in accordance with Section 03315.

3.12 CONCRETE FOR ENCASEMENT

- A. Encasement concrete shall be Class "C" concrete as specified under Section 03315, with that below pipe mixed dry.
- B. Build concrete encasement to form and dimension shown on Drawings. Take particular care to bed pipe in concrete so that complete support of pipe is made. Place encasement at sides and top where pipe will not be disturbed or floated from its bedding.
- C. Encasement shall be incidental to Work where shown on Drawings or specified herein.

3.13 CONCRETE CAP

- A. Concrete for pipe cap shall be Class "A" concrete as specified under Section 03315. Build caps with shape and dimensions shown on Drawings. Precast caps are allowed.

3.14 STUBS, BULKHEADS, AND MISCELLANEOUS WORK

- A. Furnish material and labor required to construct stubs, bulkheads, and miscellaneous Work shown on Drawings or called for in the Specifications. The cost of this Work shall be included in Unit Prices Bid for manholes, structures, catch basins, inlets, and/or sewers, if applicable.
- B. Where shown on Drawings, set stubs with bulkheads in manholes or structures for connections to future sewers. Stubs shall consist of 1 length of sewer pipe with watertight plug or brick and cement bulkhead. Stubs shall have size, material, and class shown on Drawings and/or specified herein under this Section.

3.15 CATCH BASIN LEADS

- A. Construct catch basin leads as shown on Drawings. Catch basin leads shall have size, material, and class of pipe as shown on Drawings and/or specified under "Sewer Pipe" Article.
- B. Lay leads in straight lines and at uniform grades.

3.16 CULVERT PIPE

- A. Lay pipe and end sections to the line and grade called for on Drawings. Check each pipe, as laid, with line and grade pole to ensure that this result is obtained.
- B. After the pipe and end sections are laid, carefully compact the bedding under the haunches of the pipe, and backfill the trench to 12 inches above the pipe. Place sufficient backfill after each joint is made along the sides of the pipe to offset conditions that might tend to move the pipe off line and grade. Relay any pipe found off grade or out of line.
- C. Grade, or if existing, regrade and channel ditches adjacent to new culverts so as to drain away all surface water through the culvert. The cost of this grading shall be incidental to Work under this Section.

3.17 CONNECTIONS TO EXISTING MANHOLES

- A. Provide labor and materials required for connection of sewers and catch basin leads under this Contract to existing manholes, structures, and catch basins as called for on Drawings. Wherever possible, core holes in manhole walls for new pipe connections and install resilient boots or NPC contour seal, if approved by ENGINEER. If coring is not possible, star-drill the opening and provide a smooth hand-troweled mortar finish in opening to allow installation of boot or seal. When making holes, take care to prevent debris from entering existing sewers or leads.
- B. After installation of pipe, seal manhole or catch basin around pipe, both on inside and outside of the manhole or catch basin, so that it is restored to a watertight condition. Install new flow channels in existing manholes where called for on Drawings.
- C. Install pipes made of plastic or other nonporous materials with ENGINEER-approved waterstop at manhole entry and exit points to provide watertight seal. Receive ENGINEER approval on waterstop prior to laying pipe.

3.19 WYE BRANCH CONNECTIONS

- A. Provide wye branch connections at such points as are shown on Drawings or as directed by ENGINEER. Provide size and character indicated on Drawings. Form branch connections with standard wye branches. Close by stoppers branches which will not have pipes connected to them. Stopper shall be adequate for air testing requirements. Immediately set and joint stopper bell or groove of branch outlet by same type jointing material as used for sewer pipe.
- B. In order to properly mark location of every branch connection, take accurate measurements of all branches before sewer trench is backfilled. Measurements shall indicate distance from each branch to center of nearest downstream manhole. Furnish ENGINEER with a written copy of these measurements immediately upon completion of block or sewer.
- C. In addition to measurements, provide a 1/2-inch diameter iron rod or pipe, or a 1-inch by 2-inch cypress, ash, or cedar marking stick at each branch connection of such length that it will reach from the branch up to within 6 inches of the ground surface. Set each marker in a vertical position and hold vertical while backfilling trench.
- D. Construct wyes on existing sewers with watertight joints on each end. Submit method for joining wye to the existing pipe and for supporting wye to maintain proper grade to ENGINEER for approval prior to construction.

3.20 CORED TAP

- A. For sewers 18 inches or larger in diameter, cored taps may be used in place of wyes. Make cored tap with coring machine which will create clean and circular opening in sewer pipe. The opening shall not be larger than outside diameter of service lateral pipe plus 10 percent.
- B. For rigid pipe use rubber boot such as that produced by Kor-N-Tee to connect service lateral to pipe. Use Inserta Tees for cored taps in PVC pipe 18 inches or larger internal diameter. Sewers may be pre-cored at factory if approved by ENGINEER.
- C. The service lateral shall not protrude into existing sewer.

3.21 RISER PIPE

- A. Where directed by ENGINEER or shown on Drawings, provide risers of size and type shown on Drawings and/or as listed on Bid Form.
- B. Extend risers from branch opening of sewer up to elevation of house sewer service lateral, or to such elevation as will provide existing or future service. Lay up and firmly hold riser in place. Surround riser by Class "C" concrete as shown on Drawings. Close openings in top of riser pipe with stoppers.
- C. Provide each riser with marking stick as specified above for branches.

3.22 SERVICE LATERAL CONNECTIONS

- A. Whenever indicated or noted on Drawings, install service lateral connection sewer and locate so that property owner may readily connect to building plumbing. Connections shall be as shown on Drawings and as specified herein under "Sewer Pipe" Article, with minimum grade of 1/8 inch per foot for 6-inch sewers. Place stopper of same material and joint as pipe at end of each connection. Mark stopper with a marker stick as specified before.
- B. Where new service lateral sewer must be extended to service existing building, not connected to a public sewer, locate termination of service stopper so that its extension can intersect and/or connect to building owner's existing sewerage system.
- C. Where service lateral sewer must be provided for empty lot, locate terminus where directed by ENGINEER.
- D. Install service lateral sewer at elevation required to serve present and future basement sanitary facilities. Unless directed otherwise by ENGINEER, install service to buildings without basements no higher than 8 feet below first floor elevation, or empty lots no higher than 7 feet below probable future finish building grade, or if sewer main is shallow, at minimum grade permitted by sanitary sewer main.
- E. Whenever a service connection crosses under roadway pavement which may not be disturbed, an opening may be bored to proper grade in soil beneath pavement. In case the earth is not sufficiently stable, install suitable casing pipe by boring and jacking method to enable laying of service lateral sewer through casing pipe. Install casing pipe and service lateral connection according to applicable requirements given under this Section and details shown on Drawings.

- F. Service lateral sewers made with ABS truss pipe shall have pipe SDR 23.5. Service lateral sewers made with PVC or PVCP pipe shall have pipe SDR 23.5 and gasketed joints unless otherwise noted on Drawings.

3.23 EDGE DRAINS

- A. Edge drain systems shall meet requirements of MDOT Specification for Highway Construction. Pipe materials shall be corrugated plastic tubing with geotextile pipe wrap.

3.24 CONNECTIONS TO EXISTING SEWERS

- A. When service lateral sewer or other pipe is to be connected to existing sewer, use wye, Inserta Tee, or approved tapping saddle. Wyes shall be of the same material as pipe unless otherwise approved by ENGINEER, and shall be as set forth under "Wye Branch Connections" Article. Direct taps of rigid pipes, other than cored taps, shall not be permitted unless approved in writing by ENGINEER.
- B. When a new section of sewer or wye is to be installed in-line with an existing sewer, use compression-type coupling with shear rings. Adjustable rings are required in couplings 6 inches or larger. Clamps and shear ring shall be stainless steel. The following types of couplings are approved for the Work:
 - 1. Logan LCP Coupling
 - 2. Fernco Series 1001-66

3.25 FIELD QUALITY CONTROL

- A. General:
 - 1. Conduct acceptance tests for tightness on sanitary sewers and laterals. In areas where live leads have to be connected as Work progresses, only television inspection shall be required.
 - 2. Test sewers 24 inches in diameter and smaller using low-pressure air. Also test sewers for infiltration where groundwater is above sewer invert. In areas where groundwater is more than 2 feet above the sewer crown at upstream end, air test with dewatering system in operation or use infiltration test after dewatering system is turned off and groundwater has returned to its normal level.
 - 3. Test sewers above 24 inches in diameter using infiltration or exfiltration tests as directed by ENGINEER.
 - 4. Make provisions for determining groundwater level prior to testing. ENGINEER shall be able to confirm level by visual inspection. Water level holes in manholes shall be sealed watertight after sewer has passed test.
 - 5. CONTRACTOR may, at CONTRACTOR'S option, test any or all of the sewer lines prior to backfilling. However, such tests shall be in addition to required test following backfilling of trench.
 - 6. Following completion of first section of sewer, if ENGINEER determines that there is some question as to installation of sewer, ENGINEER may direct CONTRACTOR to conduct a presumptive test to check installation for defective pipe or faulty joints before it is completely covered with backfill material.
 - 7. Provide necessary materials, equipment, and personnel to conduct tests.
 - 8. Acceptance test sections include entire length of sewer under Contract, including laterals.
 - 9. Clean and flush pipe prior to conducting acceptance tests.

10. Make tests under supervision of ENGINEER. Submit testing schedule and procedures for CONTRACTOR and approval by ENGINEER prior to start of Work.
11. For those sections of sewer that cannot pass the acceptance test, make segmented TV testing or visual inspection to examine length of sewer being tested to locate possible cracks, breaks, bad joints, or misaligned pipe sections. Remove cracks and breaks, and replace bad joints or misaligned pipe sections located by inspection. Any sewers found with defects as listed above shall be repaired to like-new condition. ENGINEER may order reconstruction of defective portion of sewer. After all repair Work has been completed, repeat test. Final acceptance of the sewer being tested will not be made until satisfactory tests have been passed.
12. Repair visible leakage in sewers or manholes even though acceptance tests have been satisfactory.

B. Air Testing:

1. Except for test times, air test concrete pipe sewers in accordance with ASTM C 924, vitrified clay pipe, in accordance with ASTM C 828, and all other sewers in accordance with ASTM F 1417. After pipe section to be checked is plugged, supply air to pipe section at a rate sufficient to maintain internal pressure of 4.0 psig. If the reach of pipe has not been backfilled, spray exposed surface of the pipe, fittings and plugs with foamable soap solution to detect by foam abnormal leakage due to cracks, holes, or improperly sealed joints. Correct sources of abnormal leakage. After all corrections are made, add air again until internal pressure of 4.0 psig is obtained. Then allow pressure to decrease to 3.5 psig, at which time a stopwatch shall be started to determine total time required for internal pressure to decrease to 2.5 psig.
2. Test equipment shall include source of compressed air, air hose, plugs, hose connections, shutoff valve, throttling valve, cage cock, monitoring pressure gauge, delicate 0.1 psi graduations pressure gauge, and stopwatch.
3. In all test pressures noted, add pressure adjustment of 0.433 psi pressure for each foot of groundwater level above invert of pipe being tested.
4. If section of sewer to be tested includes more than one pipe size, calculate test time for each size and add test times to arrive at total time for section.
5. Carefully observe safety precautions during air testing, recognizing the danger from plugs blowing out. Do not allow persons in manholes during testing.
6. Isolate pipe to be tested; plug section of pipe to be tested at each end. Plug ends of branches, laterals, and wyes which are included in test. Carefully brace plugs to prevent slippage and blowout due to the internal pressure.
7. Supply air to pipe section. Monitor air pressure so that pressure inside pipe does not exceed 5.0 psig, plus adjustment for groundwater.
8. Stabilize: When pressure reaches 4.0 psig, throttle air supply so that internal pressure is maintained between 4.0 and 3.5 psig, plus adjustment for groundwater, for at least 2 minutes. If plugs are found to leak, bleed off air, tighten plugs, and supply air again.
9. Determine rate of air loss. The control equipment consists of pressure gauges, valves, and pocket stopwatch. After allowing pressure to stabilize for 2-minute period, disconnect air supply and allow pressure to decrease to 3.5 psig. At 3.5 psig, start stopwatch to determine time required for pressure to drop to 2.5 psig. (NOTE: Make proper pressure adjustment for groundwater, where applicable, in determining beginning and end of period for 1.0 psig pressure drop). Pipeline shall be considered acceptable if time interval for 1.0 psi pressure drop is greater than holding time listed in Low Pressure Air Test Tables included in this Section. If CONTRACTOR's pressure gauge has minor graduation marks for 0.25 psi or greater, a pressure drop of only 0.5 psi will be permitted for all pipes but VCP or concrete pipe. Times for 0.5 psi drop are same as those given in this Section for VCP and concrete pipe at 1 psi drop.

C. Infiltration/Exfiltration Tests:

1. In sanitary sewers, place weirs temporarily for testing purposes in such manholes as necessary to measure amount of infiltration. Such tests at option of ENGINEER may be any length of sewer between two manholes, entire length of sewer under Contract, or any combination of sewer reaches.
2. The allowable amount of infiltration shall not be more than 200 gallons per inch diameter of sewer and laterals per mile of sewer per 24 hours. Allowable amount of infiltration shall include infiltration into manholes.
3. If, in ENGINEER's opinion, there is not sufficient groundwater for infiltration testing of various sections of sewer, conduct exfiltration tests. The allowable amount of exfiltration shall not be more than 200 gallons per inch diameter of sewer and laterals per mile of sewer per 24 hours.

D. Ring Deflection Testing:

1. A minimum of 30 days after the sewer has been installed, ring deflection testing shall be performed.
2. Test all reaches of flexible pipe (excluding truss pipe with minimum pipe stiffness of 200 psi and trench depth less than 12 feet) for vertical ring deflection under load. Testing shall be performed by accredited independent testing company unless otherwise approved by ENGINEER. Testing shall be performed by Go-No Go Gauge method for compliance to maximum deflection limits or by instruments which measure and record actual pipe deflection. The maximum allowable pipe deflection shall be 5 percent of the average inside diameter.
3. Replace sections of pipe which do not pass these tests at no cost to OWNER.

E. Television Inspection:

1. Provide materials, labor, and equipment for television inspection of all new sanitary sewers. Include necessary cleaning and pumping of sewage.
2. ENGINEER's representative shall directly supervise televising and view recordings.
3. Record sewer interior on video, which shall be turned over to OWNER. DVD format shall be used.
4. The inspection shall involve visual observation by closed-circuit television. Perform inspection at rate of speed which will allow examination of all points of infiltration, cracked or crushed pipe, defective joints, misalignment in line or grade, location of wye opening, and other defects. Precisely locate and describe by detailed statement of condition any item which, in opinion of ENGINEER, requires repair.
5. As part of television inspection, note precise location of each wye in relation to downstream manhole. Record this location on wye location sheets supplied by CONTRACTOR.
6. If camera encounters dip in sewer such that water is standing above springline of sewer pipe, and if camera lens becomes submerged because of this condition, withdraw camera rig from sewer and insert from other end as far as possible. Prevent backflooding into reach from adjacent section.
7. Provide 2 copies of notes, wye locations, and other pertinent information as part of television inspection report. Turn over 1 set of this information to ENGINEER upon completion of inspection of each line. Hold second copy of information until completion of Project, at which time assemble and turn it over to ENGINEER.

LOW PRESSURE AIR TEST TABLES
 TIME REQUIRED FOR 1.0 PSIG PRESSURE DROP
 WHEN TESTING ONE PIPE DIAMETER ONLY FOR SIZE AND LENGTH OF PIPE INDICATED.

TABLE FOR PVC, PVCP, ABS AND DI PIPE

1 Pipe Diameter (in.)	2 Minimum Time (min:sec)	3 Length for Minimum Time (ft.)	4 Time for Longer Length (sec.)	Test Time for Length (L) Shown (min:sec)								
				100 ft.	150 ft.	200 ft.	250 ft.	300 ft.	350 ft.	400 ft.	450 ft.	
4	3:46	597	0.380 L	3:46	3:46	3:46	3:46	3:46	3:46	3:46	3:46	3:46
6	5:40	398	0.854 L	5:40	5:40	5:40	5:40	5:40	5:40	5:40	5:42	6:24
8	7:34	298	1.520 L	7:34	7:34	7:34	7:34	7:36	8:52	10:08	11:24	11:24
10	9:26	239	2.374 L	9:26	9:26	9:26	9:53	11:52	13:51	15:49	17:48	17:48
12	11:20	199	3.418 L	11:20	11:20	11:24	14:15	17:05	19:56	22:47	25:38	25:38
15	14:10	159	5.342 L	14:10	14:10	17:48	22:15	26:42	31:09	35:36	40:04	40:04
18	17:00	133	7.692 L	17:00	19:13	25:38	32:03	38:27	44:52	51:16	57:41	57:41
21	19:50	114	10.470 L	19:50	26:10	34:54	43:37	52:21	61:00	69:48	78:31	78:31
24	22:40	99	13.674 L	22:47	34:11	45:34	56:58	68:22	79:46	91:10	102:33	102:33
27	25:30	88	17.306 L	28:51	43:16	57:41	72:07	86:32	100:57	115:22	129:48	129:48
30	28:20	80	21.366 L	35:37	53:25	71:13	89:02	106:50	124:38	142:26	160:15	160:15
36	34:00	66	30.768 L	51:17	76:55	102:34	128:12	153:50	179:29	205:07	230:46	230:46

TABLE FOR VCP AND CONCRETE PIPE

1 Pipe Diameter (in.)	2 Minimum Time (min:sec)	3 Length for Minimum Time (ft.)	4 Time for Longer Length (sec.)	Test Time for Length (L) Shown (min:sec)								
				100 ft.	150 ft.	200 ft.	250 ft.	300 ft.	350 ft.	400 ft.	450 ft.	
4	1:53	597	0.190L	1:53	1:53	1:53	1:53	1:53	1:53	1:53	1:53	1:53
6	2:50	398	0.427L	2:50	2:50	2:50	2:50	2:50	2:50	2:51	3:12	3:12
8	3:47	298	0.760L	3:47	3:47	3:47	3:47	3:48	4:26	5:04	5:42	5:42
10	4:43	239	1.187L	4:43	4:43	4:43	4:57	5:56	6:55	7:54	8:54	8:54
12	5:40	199	1.709L	5:40	5:40	5:42	7:08	8:33	9:48	11:24	12:50	12:50
15	7:05	159	2.671L	7:05	7:05	8:54	11:08	13:21	15:35	17:48	20:02	20:02
18	8:30	133	3.846L	8:30	9:37	12:49	16:01	19:14	22:26	25:38	28:51	28:51
21	9:55	114	5.235L	9:55	13:05	17:27	21:49	26:11	30:32	34:54	39:16	39:16
24	11:20	99	6.837L	11:24	17:57	22:48	28:30	34:11	39:53	45:35	51:17	51:17
27	12:45	88	8.653L	14:25	21:38	28:51	36:04	43:16	50:30	57:42	64:54	64:54
30	14:10	80	10.683L	17:48	26:43	35:37	44:31	53:25	62:19	71:13	80:07	80:07
36	17:00	66	15.384L	25:39	38:28	51:17	64:06	76:55	89:44	102:34	115:23	115:23
42	19:50	57	20.939L	34:54	52:21	69:48	87:15	104:42	122:09	139:36	157:03	157:03

Note: When testing two sizes of pipe simultaneously, time shall be computed by ratio of lengths involved.

Example: 400 feet of 8-inch PVC pipe and 150 feet of 6-inch VCP pipe.

$$\text{Time} = \frac{\text{Time} = \text{Length}_1 \times \text{Time}_1 + \text{Length}_2 \times \text{Time}_2}{\text{Length}_1 + \text{Length}_2}$$

$$= \frac{400 \times 10:08 + 150 \times 2:50}{400 + 150} = \frac{400 \times 608 + 150 \times 170}{400 + 150} = 489 \text{ seconds} = 8:09 \text{ (min:sec).}$$

END OF SECTION

SECTION 02635 - MANHOLES AND CATCH BASINS

PART 1 - GENERAL

1.01 SUMMARY

- A. Section Includes: Labor, materials, and equipment necessary for furnishing the fabrication, production, installation, or erection of manholes and catch basins including inlets. Concrete, excavation, and backfill shall be as specified here. Manholes and catch basins shall be complete with frames, covers, and steps. Adjustment of frames, inlets, etc., on new manholes and catch basins to meet new or existing pavement surfaces or sidewalks shall be included in Work under this Section.

1.02 REFERENCES

- A. Reference Standards:
1. ASTM A 48 Gray Iron Castings.
 2. ASTM A 536 Ductile Iron Castings.
 3. ASTM C 55 Concrete Building Brick.
 4. ASTM C 76 Reinforced Concrete Culvert, Storm Drain, and Sewer Pipe.
 5. ASTM C 139 Concrete Masonry Units for Construction of Catch Basins and Manholes.
 6. ASTM C 443 Joints for Circular Concrete Sewer and Culvert Pipe, Using Rubber Gaskets.
 7. ASTM C 472 Test Method for Physical Testing of Gypsum, Gypsum Plasters, and Gypsum Concrete.
 8. ASTM C 478 Precast Reinforced Concrete Manhole Sections.
 9. ASTM C 923 Resilient Connectors Between Reinforced Concrete Manhole Structures and Pipes.

1.03 SUBMITTALS

- A. Shop Drawings: Submit Shop Drawings covering the items included under this Section. Shop Drawing submittals shall include:
1. Dimensions and reinforcement of precast concrete units, joint details, orientation and elevation of preformed openings in riser sections, pipe-to-manhole connection details, casting details, and certification papers.
- B. Quality Control Submittals: All precast concrete manhole sections, resilient connectors between manhole sections and pipes and castings delivered to Site shall be preceded or accompanied by certification papers or stamped markings showing that the materials have been tested in accordance with applicable standard testing procedures and that the materials meet the Specifications.

PART 2 - PRODUCTS

2.01 MANUFACTURERS

- A. Subject to compliance with specified requirements, manufacturers offering products which may be incorporated in Work include:
1. Cast Iron Manhole Steps:
 - a. James B. Clow and Sons.

- b. East Jordan Iron Works.
- c. Neenah Foundry Co.
- 2. Steel-Reinforced Manhole Plastic Steps:
 - a. Cast-in-Place:
 - 1) M.A. Industries, Inc. PS1-PF.
 - b. Masonry:
 - 1) M.A. Industries, Inc. PS1-B.
 - c. Mechanical Lock:
 - 1) M.A. Industries, Inc. PS1-PF.
- 3. Frames and Covers:
 - a. James B. Clow and Sons.
 - b. East Jordan Iron Works.
 - c. Neenah Foundry Co.

2.02 MANHOLES

- A. Manholes on new or existing storm sewers, water mains, and pumping mains, shall be precast reinforced concrete unless otherwise noted on Drawings.
- B. Manhole slabs shall be constructed of Class A concrete; manhole channels and fillets shall be constructed of Class C concrete. Unless otherwise directed, all surfaces of concrete channels and fillets shall be screeded and floated to a smooth, uniform surface and troweled to a hard finish.

2.03 CATCH BASINS

- A. Catch basins shall be constructed of precast reinforced concrete units. These precast units shall conform to the requirements of ASTM. Inside grouting with either cold-applied, ready-to-use plastic joint-sealing compound or rubber gasket shall be used to connect the units.
 - 1. As an alternate, the use of concrete manhole block conforming to ASTM will be permitted. If block is used, a mortar coating shall be applied the same as with masonry construction of manholes.
- B. If noted on Drawings, catch basins shall be constructed with sumps.
- C. Foundations shall be constructed as a cast-in-place concrete slab according to details given on Drawings or precast reinforced concrete base slabs as specified under Manholes.

2.04 MANHOLE STEPS

- A. Manhole steps shall be asphalt-coated cast iron or be steel-reinforced, high-density polypropylene plastic meeting OSHA requirements. They shall be a minimum 10 inches wide and placed a maximum of 16 inches apart.

2.05 FRAMES AND COVERS

- A. Cast iron frames and covers shall be furnished and placed on each manhole by CONTRACTOR. Casting materials shall conform to ASTM A 48, Class 30 or better for gray iron, or ASTM A 536 for ductile iron. Casting shall be free of defects and shall be smooth and well cleaned by shot blasting. Castings shall be of the size and type as called for on Drawings. Castings shall be set flush with

sidewalk, pavement, or ground surface and shall be securely cemented in place. In gravel streets, covers shall be set 4 inches below the surface.

- B. Where noted on Drawings, bolted gasketed frames and covers shall be provided. The frames shall be anchored to the concrete manhole sections according to details shown on Drawings.

2.06 PRECAST REINFORCED CONCRETE MANHOLES

- A. Precast manhole base sections, riser sections, conical sections, flat slab tops, grade rings, manhole steps and ladders shall meet the requirements of ASTM C 478.
- B. Premium modified tongue and groove joints with rubber gaskets meeting the requirements of ASTM C 443 shall be provided for all sanitary sewer manholes. Joints in storm sewer, water main, and pumping main manholes shall be either premium joint as specified for sanitary manholes or shall be tongue and groove with a cold-applied plastic joint-sealing compound and primer.
 - 1. The joints around the inside circumference of the manhole shall be pointed with cement mortar. All holes provided for handling and lifting shall be filled with mortar and made watertight.
- C. Foundations for precast manholes shall be constructed as a cast-in-place concrete slab, precast reinforced concrete slab, or precast reinforced concrete base riser section with integral floor as specified under Division 3 and as shown on Drawings. Steel reinforcing for precast base slabs shall meet the requirements of ASTM C 472.

PART 3 - EXECUTION

3.01 DEWATERING

- A. Dewatering of Site shall be as specified under Section 02240 - Dewatering.
- B. Subbase preparation is an adequate foundation for all manhole structures and shall be obtained by removal and replacement of unsuitable materials with 4 inches minimum crushed stone, or by such other means as provided for foundation preparation of the connected sewers.

3.02 EXCAVATION AND BACKFILL

- A. Excavation and backfill shall be in accordance with Section 02315.
- B. The excavation shall be of sufficient dimensions to provide ample space for sheeting and bracing where sheeting and bracing are required, and ample space to perform Work in a satisfactory manner.
- C. When the earth at the normal depth of the structure is unsuitable for a foundation for the structure, such unsuitable materials shall be removed as required by ENGINEER and replaced with MDOT Class II material.

3.03 BEDDING

- A. Precast base section shall be placed on a well-graded granular bedding course conforming to the requirements for sewer bedding, but not less than 4 inches in thickness and extending to the limits of

the excavation. The bedding course shall be firmly tamped and made smooth and level to ensure uniform contact and support of the precast element.

3.04 PRECAST REINFORCED CONCRETE MANHOLES

- A. All lift holes and all joints between precast elements in manhole shall be thoroughly wetted and then completely filled with mortar, smoothed, and painted both inside and out to ensure watertightness.
- B. Precast sections shall be placed and aligned to provide vertical sides and vertical alignment of the manhole steps. The complete manhole shall be rigid, true to dimensions and watertight.

3.05 PLACING OF CASTINGS, GRADE RINGS, AND TOP SECTIONS

- A. Castings placed on concrete surface shall be set in full mortar beds. The mortar shall be mixed in proportion of 1 part Portland cement to 2 parts sand, by volume, based on dry materials. Castings shall be set accurately to the finished elevation so that no subsequent adjustment will be necessary, or unless otherwise specified by ENGINEER.
- B. Where Work is in paved streets or areas which have been brought to grade, not more than 15 inches shall be provided between the top of the cone or slab and the underside of the manhole casting for adjustment of the casting to street grade.
- C. Where Work is in unpaved streets or alleys, provide not less than 12 inches of adjusting rings between the top of the cone or slab and the underside of the manhole casting for adjustment of the casting to finished grade. Set the top of the manhole casting 5 inches below finished grade, unless otherwise directed by ENGINEER.
- D. Where Work is in cultivated agricultural areas, bury the top of the manhole casting 3 feet, and in noncultivated areas, set the casting flush with the finished grade, unless otherwise directed by ENGINEER.
- E. Where the last manhole section is a reducing cone and it is set to final grade as required by ENGINEER, if as part of the continuous Work it becomes necessary to lower this casting and the adjustment entails going below the cone, compensation to CONTRACTOR will be allowed for said adjustment and changing of the manhole stacks.
- F. Point up and make watertight adjusting rings used to set the casting to grade.

3.06 CHANNELS AND INVERTS

- A. Channels and inverts shall be made to conform accurately to the sewer characteristics and grades and shall be brought together smoothly with well-rounded junctions.

3.07 REMOVALS, REPLACEMENTS, AND MODIFICATIONS

- A. Remove existing manholes where indicated on Drawings or as directed by ENGINEER. Remove frame and cover and deliver to OWNER. Bulkhead all abandoned pipes and either remove the manhole and backfill the area as specified under "Excavation and Backfill," or, if in good condition, remove to a depth of 24 inches below grade and fill with granular fill materials.

- B. Remove existing catch basins where indicated on Drawings or as directed by ENGINEER. Remove frame and cover and deliver to OWNER. Completely break up masonry, or pipe, and remove and dispose. Bulkhead all abandoned pipe connections at both ends where accessible. Backfill the area occupied by existing catch basins after their removal as specified under Section 02315.
- C. Where indicated on Drawings and/or as directed by ENGINEER, fit existing catch basins to be retained with a new frame and cover of the type noted on Drawings including all necessary work required to adjust to grade. Where indicated on Drawings or as directed by ENGINEER, fillet existing sumps with Class C concrete and bulkhead abandoned leads. Work shall be considered incidental to construction of the new catch basin lead.
- D. Where noted on Drawings and/or as directed by ENGINEER, remove existing manhole and/or catch basin castings and replace with a new casting as specified here before.

END OF SECTION

SECTION 02740 - HOT MIX ASPHALT PAVING

PART 1 - GENERAL

1.01 SUMMARY

- A. Extent of hot mix asphalt (HMA) paving Work is shown on Drawings.

1.02 REFERENCES

- A. MDOT Standard Specifications for Construction, Most Recent Edition.
- B. ASTM:
 - 1. D 5581: Test Method for Resistance to Plastic Flow of Bituminous Mixtures Using Marshall Apparatus (6-inch Diameter Specimen).

1.03 DESIGN REQUIREMENTS

- A. HMA pavement restoration shall be one of the following types:
 - 1. Type A: 1-1/2-inch, HMA leveling course over gravel base with 1-1/2-inch, HMA wearing course in trench areas.
 - 2. Type B: 1-1/2-inch, HMA leveling course over gravel base in trench areas with 1-1/2-inch, HMA wearing course over entire width of pavement.
 - 3. Type C: 1-1/2-inch, HMA wearing course on 8-inch concrete base in trench areas.
 - 4. Type D: 1-1/2-inch, HMA wearing course in trench areas over 8-inch HMA base course.
- B. All HMA driveways shall be 1-1/2-inch HMA leveling course and 1-1/2-inch HMA wearing course on a 6-inch thick compacted gravel base. If an existing driveway has a thicker HMA cross-section, the difference shall be made up using HMA base.

1.04 SUBMITTALS

- A. Shop Drawings: Submit Shop Drawings covering the items included under this Section.
- B. Quality Assurance Submittals:
 - 1. Provide copies of materials certificates, signed by material producer and CONTRACTOR, certifying that each material item complies with or exceeds specified requirements.
 - 2. Provide a laboratory-designed, Marshall mix design for all HMA mixtures. The mix design shall include, at a minimum, the asphalt content, compacted mixture specific gravity theoretical maximum specific gravity, air voids, voids filled with asphalt (VFA), voids mineral aggregate (VMA), mix proportions, stability, flow, aggregate gradation, crush content, and job mix formula.

1.05 QUALITY ASSURANCE

- A. Codes and Standards: Comply with MDOT Standard Specifications for Construction, most recent edition.

1.06 SITE CONDITIONS

- A. Weather Limitations: Apply prime and tack coats when ambient temperature is above 50 degrees F (10 degrees C), and when temperature has not been below 35 degrees F (1 degree C) for 12 hours immediately prior to application. Do not apply when base is wet or contains an excess of moisture.
 - 1. Construct asphalt concrete surface course when atmospheric temperature is above 40 degrees F (4 degrees C), and when base is dry. HMA base course over 2 inches thick may be placed when air temperature is above 35 degrees F (-1 degree C) and rising. HMA may not be placed between November 15 and May 5.
- B. Establish and maintain required lines and elevations. Grade control shall be according to MDOT standards.

PART 2 - PRODUCTS

2.01 MATERIALS

- A. Use locally available materials and gradations which meet the specifications requirements and exhibit a satisfactory record of previous installations.
 - 1. Base Course Aggregate: MDOT Specification 22A.
 - 2. Surface Course Aggregate: MDOT Specification 22A.
 - 3. Mineral Filler: MDOT Specification 3MF.
 - 4. Asphalt Cement: Asphalt penetration (viscosity) rate of 120 to 150.
 - 5. Bond Coat: MDOT Specification SS-1h or CSS-1h.
 - 6. Lane Marking Paint: Chlorinated rubber-alkyd type, AASHTO M 248 (FS TT-P-115), Type III.

2.02 ASPHALT-AGGREGATE MIXTURE

- A. HMA mixtures shall be MDOT 13A or 36A, furnished and placed in accordance with MDOT Specifications 501 and 502. Aggregate Wear Index shall be 220 for local roads and 260 for collection and major roads.
- B. When tested at the optimum asphalt content in accordance with ASTM D 5581, the bituminous mixture shall meet the requirements for stability, 1,100 pounds, flow, 8-16 hundredths of an inch, air voids 3.0 percent, and voids in mineral aggregate, 13.5 percent.

PART 3 - EXECUTION

3.01 SURFACE PREPARATION

- A. Proof roll prepared subbase surface to check for unstable areas and areas requiring additional compaction. Do not begin base construction or paving Work until deficient subbase areas have been corrected and are ready to receive paving.
- B. Pavement along edges of existing HMA surfaces shall be removed as directed by ENGINEER to construct butt joints.

- C. Tack Coat: Apply to contact surfaces of previously constructed HMA or Portland cement concrete and surfaces abutting or projecting into HMA pavement. Distribute at rate of 0.10 gallon per square yard of surface. Apply to all edges of concrete curb and gutter.
 - 1. Allow to cure until at proper condition to receive paving.
- D. Exercise care in applying HMA materials to avoid smearing of adjoining concrete surfaces. Remove and clean damaged surfaces.

3.02 PLACING MIX

- A. Place HMA mixture on prepared surface, spread and strike-off in accordance with MDOT Specifications. Spread mixture at minimum temperature of 225 degrees F (107 degrees C). Place inaccessible and small areas by hand. Place each course to required grade, cross-section, and compacted thickness as shown on Drawings.
- B. Paver Placing: Place in strips to line up with lane lines in accordance with MDOT Specifications.
- C. Joints: Make joints between old and new pavements or between successive days' work, to ensure continuous bond between adjoining Work. Construct joints to have same texture, density, and smoothness as other sections of HMA course. Clean contact surfaces and apply tack coat. All joints on new pavement shall be vertical joints. Joints on old to new pavement shall be butt joints.

3.03 ROLLING

- A. Begin rolling when mixture will bear roller weight without excessive displacement.
 - 1. Compact mixture with hot hand tampers or vibrating plate compactors in areas inaccessible to rollers.
- B. Breakdown Rolling: Accomplish breakdown or initial rolling immediately following rolling of joints and outside edge. Check surface after breakdown rolling, and repair displaced areas by loosening and filling, if required, with hot material.
- C. Second Rolling: Follow breakdown rolling as soon as possible, while mixture is hot. Continue second rolling until mixture has been thoroughly compacted.
- D. Finish Rolling: Perform finish rolling while mixture is still warm enough for removal of roller marks. Continue rolling until roller marks are eliminated and course has attained maximum density.
- E. Patching: Remove and replace paving areas mixed with foreign materials and defective areas. Cutout such areas and fill with fresh, HMA. Compact by rolling to maximum surface density and smoothness.
- F. Protection: After final rolling, do not permit vehicular traffic on pavement until it has cooled and hardened.
 - 1. Erect barricades to protect paving from traffic until mixture has cooled enough not to become marked.

3.04 TRAFFIC AND LANE MARKINGS

- A. Sweep and clean surface to eliminate loose material and dust.

- B. Striping: Use chlorinated-rubber base traffic lane-marking paint, factory-mixed, quick-drying, and nonbleeding; color Yellow or White.
- C. Do not apply traffic and lane-marking paint until layout and placement has been verified with ENGINEER.
- D. Apply paint with mechanical equipment to produce uniform straight edges. Apply in 2 coats at manufacturer's recommended rates.

3.05 FIELD QUALITY CONTROL

- A. In-place HMA courses will be tested for compliance with requirements for thickness and surface smoothness by OWNER. CONTRACTOR shall repair or remove and replace unacceptable paving as directed by ENGINEER.
 - 1. In-place compacted thickness will not be acceptable if exceeding following allowable variation from required thickness:
 - a. Base Course: 1/4 inch, plus or minus.
 - b. Surface Course: 1/4 inch, plus or minus.
 - 2. Surface Smoothness: Test finished surface of each HMA course for smoothness, using 10-foot straightedge applied parallel with, and at right angles to centerline of paved area. Surfaces will not be acceptable if exceeding the following tolerances for smoothness.
 - 3. Base Course Surface:
 - a. Lower Courses: 3/4 inch.
 - b. Top Course: 3/8 inch.
 - 4. Leveling and Wearing Course Surface:
 - a. Multiple Course Construction:
 - 1) 1/8 inch for top course.
 - 2) 1/4 inch for lower course.
 - b. Single Course Construction: 1/4 inch.

END OF SECTION

SECTION 02750 - PORTLAND CEMENT CONCRETE PAVING

PART 1 - GENERAL

1.01 SUMMARY

- A. Section Includes: Extent of Portland cement concrete paving is shown on Drawings, including curbs, gutters, walkways, and pavement.
- B. Related Sections:
 - 1. Prepared subbase is specified in under Section 02310.
 - 2. Concrete and related materials are specified in Section 03315.

1.02 SUBMITTALS

- A. Provide samples, manufacturer's product data, test reports, and materials' certifications as required in referenced Sections.

1.03 QUALITY ASSURANCE

- A. Codes and Standards: Comply with Michigan Department of Transportation (MDOT) Standard Specifications for Construction, Most Recent Edition.

1.04 PROJECT CONDITIONS

- A. Traffic Control: Maintain access for vehicular and pedestrian traffic as required for other construction activities.

PART 2 - PRODUCTS

2.01 GENERAL

- A. Materials for forms, steel reinforcement, joint materials, and curing materials shall comply with MDOT Standard Specifications if not specified in Section 03315.

2.02 CONCRETE MIX, DESIGN, AND TESTING

- A. Comply with requirements of Section 03315 for concrete mix design, sampling, testing, quality control, and as specified in this Section.

2.03 WHEEL STOPS

- A. Precast of 3,500 psi air-entrained concrete approximately 6 inches high, 9 inches wide, and 7 feet long, with chamfered corners and drainage slots on underside.

2.04 CONCRETE RAMPS

- A. Ramps shall be constructed 6 inches thick and to the width and slope shown on Drawings using Class A concrete. Type of ramp shall be as noted on Drawings for different intersection conditions.

2.05 CONCRETE DRIVEWAYS

- A. All concrete driveways shall be Class A concrete, 6 inches thick. All driveways shall have welded wire fabric, 6-inch by 6-inch, W1.4 by W1.4 for the full extent of new concrete paving. Joints shall be as specified in concrete work and/or concrete pavements.

2.06 CONCRETE SIDEWALKS

- A. Concrete sidewalks shall be 4 inches thick (6 inches thick at driveway crossings) and to the width as shown on Drawings or to match existing walks. Concrete shall be Class A.

2.07 CONCRETE ROADWAYS

- A. Pavement surfaces shall be as shown on Drawings. Thickness shall be as shown on Drawings or equal to that removed but in no case less than 6 inches.
- B. Concrete for pavements and bases shall be Class A concrete.
- C. For pavement replacement, reinforcing steel shall be similar to that in the existing pavement and shall provide the same cross-sectional area of reinforcement per foot as the existing pavement.

2.08 CONCRETE CURB AND GUTTERS

- A. Concrete curb and gutter shall be as shown on Drawings or shall have the same cross-section as that removed using Class A concrete and in accordance with OWNER's standards.

PART 3 - EXECUTION

3.01 SURFACE PREPARATION

- A. Remove loose material from compacted subbase or base surface immediately before placing concrete.

3.02 FORM CONSTRUCTION

- A. Set forms to required grades and lines, braced and secured. Install forms to allow continuous progress of Work and so that forms can remain in place at least 24 hours after concrete placement.
- B. Check completed formwork for grade and alignment to following tolerances:
 - 1. Top of forms not more than 1/8 inch in 10 feet.
 - 2. Vertical face on longitudinal axis, not more than 1/4 inch in 10 feet.
- C. Clean forms after each use and coat with form release agent as required to ensure separation from concrete without damage.

D. Slope step treads at 1/4 inch per foot to drain.

3.03 REINFORCEMENT

A. Locate, place, and support reinforcement as specified in Section 03315 unless otherwise indicated.

3.04 CONCRETE PLACEMENT

A. Comply with requirements of Section 03315 for mixing and placing concrete and as specified in this Section.

B. Do not place concrete until subbase, base, and forms have been checked for line and grade. Moisten subbase/base if required to provide a uniform dampened condition at time concrete is placed. Do not place concrete around manholes or other structures until they are at required finish elevation and alignment.

C. Place concrete by methods that prevent segregation of mix. Consolidate concrete along face of forms and adjacent to transverse joints with internal vibrator. Keep vibrator away from joint assemblies, reinforcement, or side forms. Use only square-faced shovels for hand spreading and consolidation. Consolidate with care to prevent dislocation of reinforcing, dowels, and joint devices.

1. Use bonding agent at locations where fresh concrete is placed against hardened or partially hardened concrete surfaces.

2. Deposit and spread concrete in a continuous operation between transverse joints as far as possible. If interrupted for more than 1/2 hour, place a construction joint.

3. When adjacent pavement lanes are placed in separate pours, do not operate equipment on concrete until pavement has attained sufficient strength to carry loads without injury.

D. Fabricated Bar Mats: Keep mats clean and free from excessive rust, and handle units to keep them flat and free of distortions. Straighten bends, kinks, and other irregularities or replace units as required before placement. Set mats for a minimum 2-inch overlap to adjacent mats.

1. Place concrete in two operations; strike off initial pour for entire width of placement and to the required depth below finish surface. Lay fabricated bar mats immediately in final position. Place top layer of concrete, strike off, and screed.

2. Remove and replace portions of bottom layer of concrete that have been placed more than 15 minutes without being covered by top layer or use bonding agent if acceptable to ENGINEER.

E. Curb and Gutter: Automatic machine may be used for curb and gutter placement at CONTRACTOR's option. If machine placement is to be used, submit revised mix design and laboratory test results that meet or exceed minimums specified. Machine placement must produce curbs and gutters to required cross-section, lines, grades, finish, and jointing as specified for formed concrete. If results are not acceptable, remove and replace with formed concrete as specified.

3.05 JOINTS

A. Construct expansion, weakened plane (contraction), and construction joints true to line with face perpendicular to surface of concrete. Construct transverse joints at right angles to the centerline unless otherwise indicated.

- B. When joining existing structures, place transverse joints to align with previously placed joints unless otherwise indicated.
- C. Joints shall be of the type and location as shown on Drawings. Joints shall be constructed in accordance with MDOT Specifications.

3.06 CONCRETE FINISHING

- A. After striking off and consolidating concrete, smooth surface by screeding and floating. Use hand methods only where mechanical floating is not possible. Adjust floating to compact surface and produce uniform texture.
- B. After floating, test surface for trueness with a 10-foot straightedge. Distribute concrete as required to remove surface irregularities, and refloat repaired areas to provide a continuous smooth finish.
- C. Work edges of slabs, gutters, back top edge of curb, and formed joints with an edging tool and round to 1/2-inch radius unless otherwise indicated. Eliminate tool marks on concrete surface.
- D. After completion of floating and when excess moisture or surface sheen has disappeared, complete troweling and finish surface as follows:
 - 1. Broom finish by drawing a fine-hair broom across concrete surface perpendicular to line of traffic. Repeat operation if required to provide a fine line texture acceptable to ENGINEER.
 - 2. On inclined slab surfaces, provide a coarse, nonslip finish by scoring surface with a stiff-bristled broom, perpendicular to line of traffic.
 - 3. Burlap finish by dragging a seamless strip of damp burlap across concrete, perpendicular to line of traffic. Repeat operation to provide a gritty texture acceptable to ENGINEER.
- E. Do not remove forms for 24 hours after concrete has been placed. After form removal, clean ends of joints and point-up any minor honeycombed areas. Remove and replace areas or sections with major defects as directed by ENGINEER.

3.07 SIDEWALKS

- A. Forms shall be of metal or wood, straight and free of distortion, and of sufficient strength to resist springing during the placing of concrete. Forms shall be securely staked, braced, and tied to the required line and grade. Flexible steel or adequately sized lumber may be used for short radius forms.
- B. The walk subgrade shall be compacted to 95 percent compaction by tamping. After wetting the subgrade, the concrete shall be placed to the proper depth and spaded along the form faces.
- C. Concrete shall be alternately tamped and screeded until all voids are removed and the surface has been brought to the required grade. The surface shall then be floated to produce a smooth, dense surface, free from irregularities. All edges and joints shall be rounded to a radius of 1/4 inch with an edging tool and trowel. As soon as all excess moisture has disappeared, the surface shall be finished by light brooming.
- D. Walks shall be divided into blocks approximately square, using slab division forms or by cutting joints after floating. These joints shall be 1/2-inch deep by 1/8 to 1/4 inch in width and shall be finished smooth and true to line. Bituminous expansion joints shall be provided at intervals of 50 feet

and at junctions with structures and curbs. Control joints shall be located between expansion joints at intervals equal to the sidewalk width.

- E. As soon as concrete surfaces have hardened sufficiently to prevent marring, they shall be covered by an approved curing compound, or they shall be thoroughly wetted and cured by an approved method for a period of 6 days unless otherwise directed by ENGINEER.

3.08 PAVEMENT

- A. The surface of concrete pavements shall be properly consolidated and struck off to such elevations so as to match adjacent pavement and made uniform by transverse floating. As soon as all excess moisture has disappeared, the pavement shall be given a final light brooming finish by dragging a seamless strip of damp burlap or cotton fabric. Edges of all joints shall be tooled.
- B. As soon as concrete surfaces have hardened sufficiently to prevent marring, they shall be covered by an approved curing compound, or they shall be thoroughly wetted and cured by an approved method for a period of 6 days unless otherwise directed by ENGINEER.

3.09 CURB AND GUTTER

- A. Concrete curb and gutter shall be placed prior to the placement of other types of roadway surfaces including concrete pavements.
- B. Curb and gutter to be replaced shall be determined by ENGINEER and shall include any cracked or broken sections and any sections which have settled 0.25 inch or more.
- C. Forms shall be complete front and back type. Back forms resulting in hand forming the curb and gutter will not be allowed. Forms shall be of metal, straight and free of distortion and of sufficient strength to resist springing during the placing of concrete. Forms shall be securely staked, braced, and tied to the required line and grade. Flexible steel or adequately sized lumber may be used for short radius forms.
- D. One (1) -inch expansion joints shall be placed opposite expansion joints in an abutting pavement. If curb or curb and gutter do not abut a concrete pavement, place expansion joints at all spring lines of street returns. If intersecting streets are more than 300 feet apart, place expansion joints at 200-foot intervals. For MDOT Standard Details A, B, C5, C6, and D curb and gutter, place expansion joints in abutting pavement.
- E. If the structure does not abut a concrete pavement or base, contraction joints shall be placed at approximately 100-foot intervals.
- F. Intermediate plane of weakness joints shall be placed at approximately 10-foot intervals between other joints as called for above.
- G. Curb returns and curb cuts for driveways shall be installed as required.
- H. The gutter and top of curb shall not vary more than 3/16 inch in 10 feet when checked with a 10-foot straightedge.

- I. After the back forms are removed, honeycomb and minor defects shall be filled with mortar composed of 1 part Portland cement and 2 parts sand.
- J. As soon as concrete surfaces have hardened sufficiently to prevent marring, they shall be covered by an approved curing compound, or they shall be thoroughly wetted and cured by an approved method for a period of 6 days unless otherwise directed by ENGINEER.

3.10 CURING

- A. Protect and cure finished concrete paving in compliance with applicable requirements of Section 03315. Use membrane-forming curing and sealing compound or approved moist-curing methods.

3.11 REPAIRS AND PROTECTIONS

- A. Repair or replace broken or defective concrete as directed by ENGINEER.
- B. Protect concrete from damage until acceptance of Work. Exclude traffic from pavement for at least 14 days after placement. When construction traffic is permitted, maintain pavement as clean as possible by removing surface stains and spillage of materials as they occur.
- C. Sweep concrete pavement and wash free of stains, discolorations, dirt, and other foreign material just before final inspection.

END OF SECTION

SECTION 02805 - RESTORATION WORK

PART 1 - GENERAL

1.01 SUMMARY

- A. Section Includes: Work including the replacement of all permanent type roadway bases and surfaces, concrete sidewalks, curbs and gutters, trees, lawns, and driveways damaged or removed due to the construction of the pipe and appurtenant structures. All such Work shall be in accordance with the Best Modern Practice, OWNER's standards, and/or as specified herein.

1.02 REFERENCES

- A. MDOT Standard Specifications for Construction, Most Recent Edition.

1.03 SUBMITTALS

- A. Shop Drawings: Submit Shop Drawings covering the items included under this Section. Shop Drawing submittals shall include:
 - 1. Material Certificates: Provide copies of materials certificates signed by materials producer and CONTRACTOR, certifying that each materials item complies with or exceeds specified requirements.

1.04 QUALITY ASSURANCE

- A. Certification: CONTRACTOR shall submit certificates of compliance with applicable MDOT Standard Specifications.

1.05 SITE CONDITIONS

- A. Weather Conditions: Construct asphalt concrete surface course when atmospheric temperature is above 40 degrees F (4 degrees C), and when base is dry. Bituminous base course over 2 inches thick may be placed when air temperature is above 35 degrees F (1 degree C) and rising. Asphalt may not be placed between November 15 and May 5.

PART 2 - PRODUCTS

2.01 AGGREGATE BASE

- A. Aggregate base shall be constructed with not less than 12 inches of compacted aggregate placed in two 6-inch layers. Aggregate base shall meet requirements of MDOT Specification for 21A or 22A aggregate. Aggregate base shall extend beyond pavements to match existing aggregate or a minimum of 24 inches.

2.02 AGGREGATE SURFACE

- A. Aggregate surface shall be constructed with not less than 12 inches of aggregate placed in two 6-inch layers. Aggregate surface shall meet MDOT Specification No. 22A.

2.03 BITUMINOUS BASE

- A. Bituminous base shall have a completed thickness of 8 inches, placed and compacted in two 4-inch layers. Bituminous base shall meet the requirements of Bituminous Mixture No. 500-20C of MDOT Specification 7.10. Asphalt cement shall have an asphalt penetration (viscosity) rate of 120-150. A bituminous bond coat meeting MDOT Specification SS-1h or MS-2a shall be applied to each succeeding layer of bituminous material at the rate of 0 - 0.10 gallon per square yard.

2.04 BITUMINOUS PAVEMENT

- A. Bituminous pavement shall be one of the following types:
 - 1. Type A: 1-1/2-inch leveling course over aggregate base with 1-1/2-inch wearing course in trench areas.
 - 2. Type B: 1-1/2-inch leveling course over aggregate base in trench areas with 1-1/2-inch wearing course over entire width of pavement.
 - 3. Type C: 1-1/2-inch wearing course on 8-inch concrete base in trench areas.
 - 4. Type D: 1-1/2-inch wearing course in trench areas over bituminous base course.
- B. Bituminous mixtures shall be furnished and placed in accordance with MDOT Specification 7.10 with no restriction for the "Aggregate Wear Index."
- C. Asphalt cement shall have an asphalt penetration (viscosity) rate of 120-150. Aggregate required shall be 20AA. When tested at the optimum asphalt content in accordance with ASTM D 1559, the bituminous mixture shall meet the requirements for stability; 1,100 pounds; flow, 8-18 hundredths of an inch; and voids in mineral aggregate, 15.0 percent, as specified in Table 7.10-1 of MDOT Specifications. The maximum allowable deviations permitted from the approved Job-Mix Formula shall be as shown in Table 7.10-3 of MDOT Specifications.
- D. At CONTRACTOR's expense, a qualified laboratory shall furnish ENGINEER a Job-Mix Formula in accordance with above criteria. After Job-Mix Formula is established, the aggregate gradation and the bitumen content of the bituminous mixture furnished for Work shall be maintained within the uniformity tolerance limits permitted in Table 7.10-3, and within the master gradation range as specified in Table 7.10-2 of MDOT Specifications.

2.05 CONCRETE ROADWAYS

- A. Concrete pavement surfaces shall be replaced with concrete where shown on Drawings. Thickness shall be equal to that removed, but in no cases less than 6 inches.
- B. Concrete for pavements and bases shall be Class A concrete.
- C. Replacement of reinforcing steel shall be similar to that in the existing pavement and shall provide the same cross-sectional area of reinforcement per foot as the existing pavement.

2.06 GRAVEL DRIVEWAYS

- A. Gravel or dirt driveways removed shall be replaced with gravel, and shall be constructed to match existing thickness but with not less than 6 inches of gravel, compacted to 95 percent compaction. Gravel shall meet MDOT Specification No. 22A.

2.07 STONE DRIVEWAYS

- A. Existing stone drive surfaces removed during construction shall be replaced with washed stone, peastone, or limestone, of type and thickness that matches the existing surface. Road gravel (22A) shall not be used to replace stone drives unless authorized by OWNER and ENGINEER.

2.08 BITUMINOUS DRIVEWAYS

- A. All bituminous driveways removed shall be replaced with 1-1/2-inch leveling course and 1-1/2-inch wearing course on a 6-inch-thick compacted gravel base. If the existing driveway has a thicker bituminous cross-section, the difference shall be made up using hot-mix bituminous base as specified under "Bituminous Base."

2.09 CONCRETE DRIVEWAYS

- A. All concrete driveways removed shall be replaced with Class A concrete, 6 inches thick. All driveways replaced shall have welded wire fabric, 6-inch by 6-inch, W1.4 by W1.4, for the full extent of new concrete paving. Joints shall be as specified in concrete work and/or concrete pavements.

2.10 CONCRETE CURB AND GUTTER

- A. Concrete curb and gutter to be replaced shall have the same cross-section as that removed, or as shown on Drawings, using Class P concrete and in accordance with OWNER's standards.

2.11 CONCRETE SIDEWALKS

- A. Concrete sidewalks shall be replaced with walks 4 inches thick (6 inches thick at driveway crossings) and to the same width as the existing walks. Concrete shall be Class A.

2.12 CONCRETE RAMPS

- A. Ramps shall be constructed 6 inches thick and to the width and slope shown on Drawings using Class A concrete. Type of ramp shall be as noted on Drawings for different intersection conditions.

2.13 SEEDING

- A. Seeding shall be one of the following types:
 1. Sodded Shoulders, Slope Area, or Flat Field: 4 inches of topsoil, 20 pounds of 10-6-4 commercial fertilizer per 1,000 square feet of area, and 5 pounds of MDOT mixture roadside per 1,000 square feet of area.
 2. Flat Lawn Area: 4 inches of topsoil, fertilizer as specified above and 3 pounds of MDOT mixture Class A per 1,000 square feet of area.
- B. Sod: Provide strongly rooted sod, not less than 2 years old, free of weeds and undesirable native grasses, and machine cut to pad thickness of 3/4 inch (plus or minus 1/4-inch), excluding top growth and thatch. Provide only sod capable of vigorous growth and development when planted (viable, not dormant). Peat sod will not be acceptable.

1. Provide sod of uniform pad sizes with maximum 5 percent deviation in either length or width. Broken pads or pads with uneven ends will not be acceptable. Sod pads incapable of supporting their own weight when suspended vertically with a firm grasp on upper 10 percent of pad will be rejected.
2. Provide sod composed principally of following:
 - a. Mixed Kentucky Bluegrass (*Poa pratensis*).

2.14 TREE/SHRUB REPLACEMENT

- A. Stakes and Wrap: Trees shall be staked and wrapped. Stakes for guying shall be wood, 2-inch by 2-inch by 30 inches long, minimum size.
- B. Stakes for staking shall be sound, 4-inch-diameter, 9-foot-long cedar posts with bark skinned off for shade trees; 2-inch by 2-inch by 8 feet long for conifers under 5 feet in height.
- C. Staking wire shall be No. 12-gauge galvanized steel.
- D. Hose for covering wire shall be new or used, black or red, 2-ply, fiber-reinforced garden hose, not less than 1/2-inch inside diameter. Seconds rejected by factory are acceptable.
- E. Tree wrap shall be treated wrapping Kraft wrap or approved equal.
- F. Plant Materials:
 1. Quality and Size: Plant materials shall be sound, healthy, vigorous, and free from plant diseases and insect pests or their eggs and shall have normal, healthy root systems. All measurements such as spread, ball size, number of canes, quality designation, etc., shall be in accordance with the latest edition of AAN USA Standard for nursery stock. Trees shall be calipered 6 inches above the ground.
 2. Sources: Must be located in the same or higher hardiness zone as determined by the latest edition of the "Plant Hardiness Zone Map," Agricultural Research Service, U.S. Department of Agriculture.
 3. Plant Material Quality Assurance, Plant Material Selection and Approval Operations: All trees required by this Contract shall be tagged by CONTRACTOR at the source for inspection and approval by ENGINEER in writing at least 2 weeks prior to each desired inspection date. Photographs of materials may be required for preliminary inspection of materials from remote sources.
 4. Root Protection: Trees and shrubs shall be balled and burlapped. They shall be dug with firm, natural balls of earth of sufficient diameter and depth to encompass the fibrous and feeding root systems necessary for full recovery of the plant. Balls shall be securely wrapped with burlap and bound with cord. No balled and burlapped plant shall be planted if the ball is cracked or broken.
 5. Protection During and After Delivery: All plant material is to be delivered to Site in closed vehicles or in open vehicles with the entire load properly covered in transit for protection from drying winds. They shall be planted immediately upon delivery. No plant shall be bound with rope or wire in a manner that would damage the bark or break the branches.

PART 3 - EXECUTION

3.01 COORDINATION OF WORK

- A. Type of restoration shall be as noted on Drawings regardless of existing surface.
- B. The placing of base and surface courses shall follow immediately after backfilling the trench so that not more than 600 feet of length of trench shall be incomplete at one time. If areas of trench in excess of 600 feet are left incomplete, CONTRACTOR shall provide such necessary temporary roadway surface as directed by ENGINEER. Any material placed in the trench other than that specified shall be considered as a temporary surface and shall be removed. No payment will be allowed for temporary roadway construction.
- C. All utilities, such as catch basins, manhole castings, water valve boxes, etc., shall be adjusted prior to installation of new pavement so that the finished surface will meet such utilities smoothly when surfacing is completed.

3.02 SAW CUT JOINTS

- A. Damaged areas shall be removed by sawing a straight-cut parallel with longitudinal and transverse construction or contraction joints. No saw cuts shall be nearer than 5 feet to a longitudinal or transverse joint or to the edge of the pavement. If the damaged area is less than 5 feet from an existing joint, the existing surface shall be saw-cut 5 feet from the damaged area, removed, and replaced. If the damaged area is less than 5 feet from the edge of the pavement, the removal and replacement shall be extended to said edge of pavement.
- B. Saw cutting of concrete shall be done with a carborundum saw to a minimum depth of half the slab thickness or that depth required to cut reinforcing steel. Bituminous surfaces shall be cut full depth.
- C. After the trench is backfilled and before the pavement over the trench is replaced, all angular and ragged irregularities on the edges of the cut pavement shall be removed giving a smooth and regular edge of pavement. Payment for cut joints required shall be included under the unit price of pavement restoration.

3.03 EXCAVATION

- A. Before repaving is started, all trenches and area around structures shall be excavated or backfilled to the level of the subgrade as required by the type of pavement replacement and cross-section specified. All existing pavement that has been undercut by the excavation for the pipe or structures shall be removed. The finished subgrade shall be smoothed, trimmed, and compacted to the required grade and cross-section. Compaction of the finish subgrade shall be obtained by suitable means approved by ENGINEER.

3.04 AGGREGATE BASE

- A. Place aggregate base on a prepared subbase or subgrade in accordance with construction methods described in Section 3.01 of MDOT Specifications.

3.05 AGGREGATE PAVEMENTS

- A. Aggregate surfaces shall be replaced with aggregate. After placing aggregate, this surface shall immediately be opened to traffic and as holes and ruts appear, they shall be filled with aggregate and the surface shall be maintained as a smooth, dust-free street surface until Work is accepted by ENGINEER and OWNER.

3.06 BITUMINOUS BASE

- A. Place bituminous base on a prepared subbase or subgrade in accordance with construction methods described in Division 4 of MDOT Specifications.

3.07 BITUMINOUS PAVEMENTS

- A. Pavement surfaces shall be replaced with bituminous concrete of the type and in locations shown on Drawings. Work shall consist of saw cutting existing surfaces as herein specified under Saw Cut Joints, conditioning and treating the base course with prime or bond material and constructing thereon a bituminous concrete surface consisting of mineral aggregate, mineral filler, and bituminous material combined by a plant hot mix method per MDOT Specification. Construction methods and equipment for placing bituminous materials shall be as specified in MDOT Standard Specifications.
- B. Pavement surfaces shall be replaced to match existing widths but new pavements shall not be less than 22 feet wide.
- C. Conditioning of Base: Bituminous base shall be treated with a bond coat applied at the rate of 0 - 0.10 gallon per square yard. Bond coat shall be SS-1h or MS-2a.
- D. Leveling Course: Bituminous leveling course mixture shall be placed in one or more layers to the cross-section shown on Drawings. When the total application rate exceeds 220 pounds per square yard, the leveling course shall be applied in 2 courses. A bond coat shall be applied at the rate of 0 - 0.10 gallon per square yard between courses.
- E. Wearing Course: Following completion of the leveling course or courses, the surface shall be treated with a bond coat of 0 - 0.10 gallon per square yard. The wearing course mixture shall be placed according to the cross-section shown on Drawings in one or more courses as required.
- F. All joints in the bituminous pavements shall be vertical joints. Where the joints are allowed to set before the adjoining pavement is placed, such joints shall be treated with bond coat material.
- G. Feathering to connect new pavement to an existing pavement will not be allowed.

3.08 CONCRETE CONSTRUCTION

- A. Pavement: The surface of concrete pavements shall be properly consolidated and struck off to such elevations so as to match adjacent pavement and made uniform by transverse floating. As soon as all excess moisture has disappeared, the pavement shall be given a final light brooming finish by dragging a seamless strip of damp burlap or cotton fabric. Edges of all joints shall be tooled.
 - 1. As soon as concrete surfaces have hardened sufficiently to prevent marring, they shall be covered by an approved curing compound, or they shall be thoroughly wetted and cured by an approved method for a period of 6 days unless otherwise directed by ENGINEER.

- B. Curb and Gutter: Concrete curb and gutter shall be placed prior to the placement of other types of roadway surfaces including concrete pavements.
1. Curb and gutter to be replaced shall be determined by ENGINEER and shall include any cracked or broken sections and any sections which have settled 0.25 inch or more.
 2. Forms shall be complete front and back type. Back forms resulting in hand forming the curb and gutter will not be allowed. Forms shall be of metal, straight and free of distortion and of sufficient strength to resist springing during the placing of concrete. Forms shall be securely staked, braced, and tied to the required line and grade. Flexible steel or adequately sized lumber may be used for short radius forms.
 3. One-inch expansion joints shall be placed opposite expansion joints in an abutting pavement. If curb or curb and gutter do not abut a concrete pavement, place expansion joints at all spring lines of street returns. If intersecting streets are more than 300 feet apart, place expansion joints at 200-foot intervals. For MDOT Standard Details A, B, C5, C6, and D curb and gutter, place expansion joints in abutting pavement.
 4. If the structure does not abut a concrete pavement or base, contraction joints shall be placed at approximately 100-foot intervals.
 5. Intermediate plane of weakness joints shall be placed at approximately 10-foot intervals between other joints as called for above.
 6. Curb returns and curb cuts for driveways shall be installed as required.
 7. The gutter and top of curb shall not vary more than 3/16 inch in 10 feet when checked with a 10-foot straightedge.
 8. After the back forms are removed, honeycomb and minor defects shall be filled with mortar, composed of 1 part Portland cement and 2 parts sand.
 9. As soon as concrete surfaces have hardened sufficiently to prevent marring, they shall be covered by an approved curing compound, or they shall be thoroughly wetted and cured by an approved method for a period of 6 days unless otherwise directed by ENGINEER.
- C. Sidewalks: Forms shall be of metal or wood, straight and free of distortion, and of sufficient strength to resist springing during the placing of concrete. Forms shall be securely staked, braced, and tied to the required line and grade. Flexible steel or adequately sized lumber may be used for short radius forms.
1. The walk subgrade shall be compacted to 95 percent compaction by tamping. After wetting the subgrade, the concrete shall be placed to the proper depth and spaded along the form faces.
 2. Concrete shall be alternately tamped and screeded until all voids are removed and the surface has been brought to the required grade. The surface shall then be floated to produce a smooth, dense surface, free from irregularities. All edges and joints shall be rounded to a radius of 1/4 inch with an edging tool and trowel. As soon as all excess moisture has disappeared, the surface shall be finished by light brooming.
 3. Walks shall be divided into blocks approximately square, using slab division forms or by cutting joints after floating. These joints shall be 1/2-inch-deep by 1/8- to 1/4-inch in width, and shall be finished smooth and true to line. Bituminous expansion joints shall be provided at intervals of 50 feet and at junctions with structures and curbs. Control joints shall be located between expansion joints at intervals equal to the sidewalk width.
 4. As soon as concrete surfaces have hardened sufficiently to prevent marring, they shall be covered by an approved curing compound, or they shall be thoroughly wetted and cured by an approved method for a period of 6 days unless otherwise directed by ENGINEER.

3.09 SEEDING

- A. Wherever the pipe trench passes through an area to be seeded, the backfilling shall be carried up to the surface except the top 4 inches, which shall be selected topsoil preserved or secured elsewhere for this purpose. This topsoil shall be rich, black surface earth, free from sod, weed stalks, or debris. The trench surface shall be carefully raked to an even surface, and all stones, sticks and other debris removed therefrom.
- B. Seeded areas shall receive a proper mulch of chopped straw, jute matting, or woven Kraft paper yarn. Seed shall not be sown between June 15 and August 15, or between October 15 and April 15, or at any time when the soil has insufficient moisture to ensure proper germination, or CONTRACTOR shall provide sufficient application of water by sprinkling until a growing catch of grass is established.
- C. In areas where runoff outlets to surface water, phosphorus-based fertilizers shall be limited in use.

3.10 SODDING

- A. Lay sod within 24 hours from time of stripping. Do not plant dormant sod or if ground is frozen.
- B. Lay sod to form a solid mass with tightly fitted joints. Butt ends and sides of sod strips; do not overlap. Stagger strips to offset joints in adjacent courses. Work from boards to avoid damage to subgrade or sod. Tamp or roll lightly to ensure contact with subgrade. Work sifted soil into minor cracks between pieces of sod; remove excess to avoid smothering of adjacent grass.
- C. When sod is laid on slopes, the first row of sod shall be laid at the bottom of the slope parallel to it, with subsequent rows laid from bottom to top. On slopes steeper than 3:1, the sod shall be secured with pegs spaced at 2 feet maximum, vertically and horizontally.
- D. Water sod thoroughly with a fine spray immediately after planting.
- E. Sodded areas shall be kept moist for the maintenance period. After the sod is installed, all areas greater than 1 foot which fail to show a uniform stand of grass, shall be resodded.
- F. In areas where runoff outlets to surface water, phosphorus-based fertilizers shall be limited in use.

3.11 RECONDITIONING EXISTING LAWNS

- A. Recondition existing lawn areas damaged by CONTRACTOR's operations including storage of materials and equipment and movement of vehicles. Also recondition existing lawn areas where minor regrading is required.
- B. Provide fertilizer, seed or sod, and soil amendments as specified for new lawns, and as required, to provide a satisfactorily reconditioned lawn. In areas where runoff outlets to surface water, phosphorus-based fertilizers shall be limited in use.
- C. Provide new topsoil, as required, to fill low spots and meet new finish grades.
- D. Cultivate bare and compacted areas thoroughly to provide a satisfactory planting bed.

- E. Remove diseased and unsatisfactory lawn areas; do not bury into soil. Remove topsoil containing foreign materials resulting from CONTRACTOR's operations, including oil drippings, stone, gravel, and other loose building materials.
- F. Where substantial lawn remains but is thin, mow, rake, aerate if compacted, fill low spots, remove humps, and cultivate soil, fertilize, and seed. Remove weeds before seeding, or if extensive, apply selective chemical weed killers as required. Apply a seedbed mulch, if required, to maintain moist condition.
- G. Water newly planted lawn areas and keep moist until new grass is established.

3.12 TREE/SHRUB REPLACEMENT

- A. Trees noted on Drawing or designated by ENGINEER to be removed shall be replaced with trees of the sizes and types listed within the Ocoola Township Zoning Ordinance. All ornamental shrubs in private lawn areas that are damaged must be removed and replaced in kind, with the largest available specimen.
- B. Preparation: Tree pits shall be excavated as shown on Drawings. Subsoil dug from pits, trenches, and beds shall be disposed of by CONTRACTOR.
- C. Topsoil shall be provided in sufficient quantities to be placed:
 1. In tree pits, 6 inches in depth below the balled root and 1 foot in width around the ball.
 2. In shrub pits, 6 inches in depth below the balled or container root and 6 inches in width around it.
 3. All other planting beds shall receive a minimum of 6 inches of topsoil.
- D. Planting: CONTRACTOR is responsible for planting to correct grades and alignment and all plants shall be set so that, when settled, they will bear the same relation to finish grade as they did before being transplanted. No filling will be permitted around trunks or stems.
 1. When the plant has been properly set, the pit shall be backfilled with planting mixture, gradually filling, tamping, and settling with water. No soil in a frozen or muddy condition shall be used for backfilling. A ring of soil shall be formed around the edge of each plant to hold water.
 2. CONTRACTOR shall make adjustments in the location of plants where necessary as directed by ENGINEER.
- E. Mulching: All planting shall be mulched with a cover of shredded bark mulch.
- F. Watering: All plants shall be thoroughly soaked after planting. After each watering, all beds shall be raked and left in a complete and finished manner.
- G. In areas where runoff outlets to surface water, phosphorus-based fertilizers shall be limited in use.
- H. Pruning and Repair: Upon completion of planting, all trees and shrubs shall have been pruned and injuries repaired. The amount of pruning shall be limited to the minimum necessary to remove dead or injured twigs and branches and to compensate for the loss of roots from transplanting. Pruning shall be done in such a manner as not to change the natural habit or shape of the plant, as directed by ENGINEER. All cuts shall be made flush, leaving no stubs. Notify ENGINEER at least 1 week prior to pruning operations.

- I. Guying, Staking, and Wrapping Trees: Guying and staking shall be completed immediately after planting. Maintain guys and stakes until the end of the guarantee period. The trunks of all deciduous trees larger than 6 to 8 feet grade shall be wrapped with standard tree wrap from the first branch down to the ground and secured at every second wrap with twine.

3.13 PROTECTION

- A. Protection and Maintenance: CONTRACTOR shall assume responsibility for maintaining CONTRACTOR's Work to the end of the guarantee period. During this period, CONTRACTOR shall make a minimum of 1 maintenance trip every 4 weeks during the growing season, and as many more as necessary to keep the plantings in a thriving condition.
 1. Maintenance of plants shall consist of pruning, cultivating, weeding, watering, keeping guying taut and trees erect, raising tree balls which settle below grade, and providing such sprays as are necessary to keep the planting free of insects and diseases.
- B. Acceptance: At the end of the warranty period, final acceptance will be made by ENGINEER and OWNER, provided all requirements of the Specifications have been fulfilled.
 1. Inspection of the plantings will be made jointly by CONTRACTOR and ENGINEER at completion of planting. All plants not in a healthy growing condition shall be removed and replaced with plants of like kind, size, and quality as originally specified before close of next planting season.

END OF SECTION

SECTION 03315 - CONCRETE WORK (SEWERS)

PART 1 - GENERAL

1.01 SUMMARY

- A. Section Includes: Extent of concrete work as shown on Drawings and specified in this Section.

1.02 REFERENCES

A. ASTM:

1. A 185 Steel Welded Wire, Fabric, Plain, for Concrete Reinforcement.
2. A 497 Welded Deformed Steel Wire Fabric for Concrete Reinforcement.
3. A 615 Deformed and Plain Billet-Steel Bars for Concrete Reinforcement.
4. C 150 Portland Cement.
5. C 260 Air-Entraining Admixtures for Concrete.
6. C 309 Liquid Membrane-Forming Compounds for Curing Concrete.
7. C 494 Chemical Admixtures for Concrete.
8. C 595 Blended Hydraulic Cements.
9. C 618 Fly Ash and Raw or Calcined Natural Pozzolan for Use as a Mineral Admixture in Portland Cement Concrete.

- B. MDOT Standard Specifications for Construction, Most Recent Edition.

1.03 SUBMITTALS

- A. Shop Drawings: Submit Shop Drawings covering the items included under this Section. Shop Drawing submittals shall include:

1. Mix Design: Submit concrete mix design as early as possible, but no later than 4 weeks before scheduled pouring. Submittal shall also include a sieve analysis of the course aggregates, including the quantity of deleterious materials present.
2. Product Data: Submit data for proprietary materials and items, including reinforcement, admixtures, patching compounds, waterstops, joint systems, curing compounds, and others used under this Section.

- B. Test and Inspection Report: A written report shall be submitted to ENGINEER documenting testing and/or inspection results.

1.04 QUALITY ASSURANCE

- A. Testing: During the progress of construction and at direction of ENGINEER, perform tests to determine that the concrete complies with the compressive strength and consistency requirements.

1. ENGINEER will witness the preparation of test cylinders.
2. Provide concrete for test cylinders. Make, handle, and store test specimens. Pack and ship specimens in substantial packages to prevent damage during transit.
3. CONTRACTOR shall bear expenses of shipment and testing specimens by an approved, independent testing laboratory.

PART 2 - PRODUCTS

2.01 FORM MATERIALS

- A. Forms for Exposed Finish Concrete: Use plywood, metal, metal-framed plywood faced, or other acceptable panel materials, to provide continuous, straight, smooth, exposed surfaces. Provide largest practicable sizes to minimize number of joints and to conform to joint system shown on Drawings.
- B. Form for Unexposed Finished Concrete: Use plywood, lumber, metal, or other acceptable material. Use lumber dressed on at least two edges and one side for tight fit.

2.02 REINFORCING MATERIALS

- A. Reinforcing Bars: ASTM A 615, Grade 60, deformed.
- B. Welded Wire Fabric: ASTM A 185, welded steel wire fabric.
- C. Welded Deformed Steel Wire Fabric: ASTM A 497.

2.03 CONCRETE MATERIALS

- A. Portland Cement: ASTM C 150, Type I or Type III. Use Type III where high-early-strength is required.
- B. Blended Hydraulic Cement: Conforming to ASTM C 595, Type IP (Portland Pozzolan cement), with Pozzolan content not to exceed 20 percent by weight.
- C. Fly Ash: ASTM C 618, Type C or Type F, with loss on ignition not more than 6 percent.
- D. Aggregates: Fine aggregate - MDOT (Michigan Department of Transportation) 2NS. Coarse aggregate - MDOT 6AA.
- E. Water: Potable.
- F. Air-Entraining Admixture: ASTM C 260.
- G. Water-Reducing Admixture: ASTM C 494, Type A, and containing not more than 0.1 percent chloride ions.
- H. Curing Compound: ASTM C 309, Type 1 or Type 2, Class B. Limit moisture loss to 0.040 gm per square centimeter when applied at 200 square feet per gallon coverage.

2.04 CONCRETE MIX DESIGN

- A. Classes:
 - 1. Class A: All concrete not otherwise indicated.
 - 2. Class C: Fill within manholes, mud mats, fill under structures, encasement for piping below or adjacent to structures and encasement for floor drains, sewer inlets and similar items.
 - 3. Class F: Flowable fill for filling spaces as permitted and directed by ENGINEER

B. Proportions: Proportion concrete by volume in agreement with the following table:

Concrete Class	A	C	F
28-day Compressive strength, psi * Laboratory Trial Batch for Selecting Concrete Proportions, average 28-day	4,000	2,000	50-100
Compressive Strength, psi, design mix	4,700	2,600	N/A
Cement Content per cubic yard of concrete, sacks minimum **	6	4	0.4-3.0 12-16.0**
Water/Cement Ratio by weight, maximum	0.44	0.75	0.40-0.75
Air Content, percent by volume	5+1	NA	NA
Slump at point of placement, inches ***	2-4	3-6	NA

* 7-day compressive strength for high-early-strength concrete.

** For concrete with fly ash, values are total of cement plus fly ash (Except Class F).

*** For concrete containing HRWR admixture (superplasticizer), slump shall not exceed 8 inches after addition of HRWR to verified 2-4 inches slump concrete.

PART 3 - EXECUTION

3.01 FORMS

- A. Install forms to conform to the shape, lines, and dimensions of the structures as called for on Drawings. Forms shall be substantial and sufficiently tight to prevent leakage of mortar, and shall be properly braced or tied together to maintain position and shape. Forms shall be clean inside before concrete is poured.
- B. Reinforcement: Place bars in the exact position shown on Drawings. Fasten bars to prevent displacement while depositing concrete.
1. Space bars with a clear distance of not less than the diameter of the bar, or 1-inch. Place bars so that the distance from the surface of the concrete to the nearest surface of the nearest bars is 2 inches in slabs, walls, beams, and columns, and 3 inches in the bottom of footings (where no mud mat is used).
- C. Splicing of Reinforcement: At splices, lap bars a distance of not less than the following to ensure full bond development of each bar:

<u>Bar Size</u>	<u>Lap Length</u>	<u>Bar Size</u>	<u>Lap Length</u>
No. 3	16 inches	No. 8	38 inches
No. 4	20 inches	No. 9	42 inches
No. 5	24 inches	No. 10	50 inches
No. 6	28 inches	No. 11	62 inches

- D. Wiremesh: 14 inches overlap between outermost cross wires of each fabric.

3.02 PLACING CONCRETE

- A. Forms shall be moist when concrete is placed. Concrete shall be handled to maintain its consistency and not to permit the ingredients to separate. Place concrete in layers not over 18 inches deep. Vibrate, rod, tamp, or work into places after each layer so that no voids or segregation of the aggregate show when the forms are removed.
- B. Discharge concrete at Work within 1-1/2 hours after the cement has been added to the water or the aggregates. When the air temperature exceeds 85 degrees F, reduce the maximum permitted mixing time to 45 minutes.
- C. When depositing concrete against the ground for slabs and footings, place the concrete on undisturbed or compacted granular base moistened but free from standing water, mud, frost, and ice.

3.03 REMOVAL OF FORMS

- A. The removal of forms shall be made without damage to the concrete and in a manner to ensure complete safety to the structures. Do not remove shoring until the member has acquired sufficient strength to support safely its weight and loads placed thereon.
- B. After form removal, exposed vertical and overhead surfaces shall have burrs and fins removed, and holes filled with nonshrink nonmetallic grout. The surfaces shall be true to line, with full corners and shall be reasonably smooth.

3.04 CURING

- A. Maintain concrete in a moist condition for at least the first 7 days after placing for normal concrete, and 3 days after placing for high-early-strength concrete. This shall be done by keeping the surface continuously wet, covering it with a plastic membrane, or by the application of a curing compound approved by ENGINEER.
- B. The surfaces of concrete from which forms are removed before 7 days after placing shall be similarly protected until the concrete has been in place for 7 days.

3.05 CONCRETE WORK IN COLD WEATHER

- A. Concrete, when deposited, shall have a temperature of not less than 50 degrees F or more than 85 degrees F. During cold weather, which shall be taken to mean weather in which the temperature of the air falls as low as 40 degrees F during any part of the 24 hours which follows, the ingredients of the concrete, including the water, shall be heated immediately before being mixed.
 - 1. Do not use antifreeze additives except as allowed by ENGINEER.
 - 2. During cold weather, concrete work shall be housed, or covered with canvas or other suitable material, and shall be kept warm by salamanders or by other means which shall ensure protection from freezing during the setting period.

3.06 CONCRETE WORK IN HOT WEATHER

- A. During hot weather, concrete temperature shall be closely monitored and kept below 85 degrees F with the use of cold water or ice for mixing water.
 - 1. The total water in the concrete mix shall not exceed the quantity approved in the concrete mix design.

END OF SECTION